



PRECISE.
PASSIONATE.
UNITED.

AT A GLANCE



Boasting a remarkable workforce of over 11,500+ skilled professionals and operating across 17 diverse business lines, the Avia Solutions Group generates an impressive annual revenue surpassing the \$2 billion mark. Moreover, Avia Solutions Group is the world's largest ACMI provider, with a fleet of 192 aircraft.

With an illustrious three-decade history, JETMS Completions stands as a preeminent force within the industry, specializing in crafting exquisite aircraft interiors for both commercial and VVIP aircraft. As an integral member of the esteemed Avia Solutions Group, alongside other esteemed JETMS brand companies, we proudly contribute to a dominant leadership position in the aviation industry.

At JETMS Completions, we leverage cutting-edge technologies and possess state-of-the-art manufacturing capabilities. Our unwavering commitment to excellence is further strengthened through our strategic alliance with JetMS Interiors in Kaunas, Lithuania.

Recognized as an EASA Part 145, CAA Part 21J, CAA Part 21G, and 145 approved organization, JETMS Completions continues to solidify its standing as a revered manufacturer of commercial aviation interiors. Notably, our leadership position in refurbishment services in the UK remains unparalleled.



OPERATING IN TWO MODERN HANGARS



**6000 SQ M, BUILDING 510
IN LONDON, UK**



**7000 SQ M HANGAR
IN KAUNAS, LITHUANIA**

WE ARE CERTIFIED

- **EASA Part-145**
- **CAA UK Part-21J**
- **CAA UK Part-145**
- **ISO 9001:2015**
- **CAA UK Part-21G**
- **ASA-100**

AIRCRAFT INTERIOR COMPONENTS



- Seats, upholstery and refurbishment
- Galleys and buffet units
- Lavatories and washrooms
- Cabin class divider systems
- Wardrobes and closets
- Carpets and soft furnishings
- Bulkheads, dividers and curtains
- Crew rest areas
- Dogbox stowages
- Lining kits & refurbishment
- Cabin refurbishment programs under Part 145 (from seat overhaul to interior components)
- Sideedges, credenzas, dado panels and pull-out sideedge
- Tables
- All cabin interior components within ATA chapters 25, 38, 44, 45 and 50

DESIGN CAPABILITIES



- 3D CAD Modelling
- 2D CAD Engineering
- Drawing (electrical/mechanical)
- FEA/FEM (Nastran)
- Stress analysis
- Service bulletins
- CMM/IPC/ICA
- Flammability test plans and reports
- Static test plans and reports

LIST



CNC router | model BPF 2141

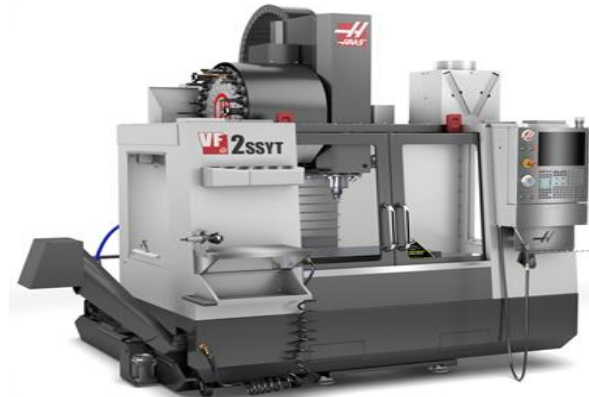

CNC mill | model VF-2SSYT-EU



CNC lathe | model ST-20Y-NGC



Guillotine | model iSHEAR-B06-3100



Press brake | model iBLEND 3100



Laser | model LM4022GFplus



FULL SPECTRUM OF SERVICES:

- NEW BUILDS
- REFURBISHMENT
- SPECIAL SERVICES
- SOME OF OUR INTERIOR DESIGN PROJECTS

The image shows the interior of a private jet cabin. The seats are white leather with dark piping. There are two rows of seats on each side of a central aisle. The cabin has a modern, clean design with recessed lighting in the ceiling and oval-shaped windows. A gold-colored overlay is on the left side of the image, containing the text "NEW BUILDS".

NEW BUILDS

New Builds

Boeing B767 front row ottoman units / interface with first class seats; full design & EASA certification achieved

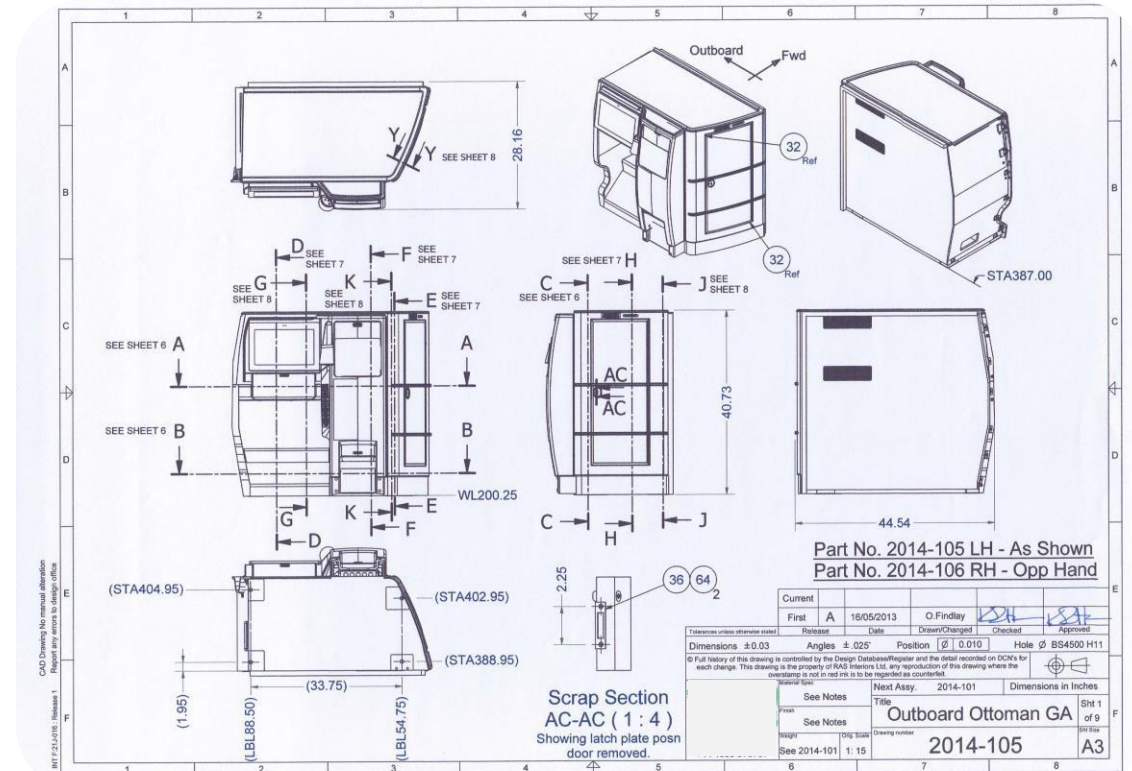
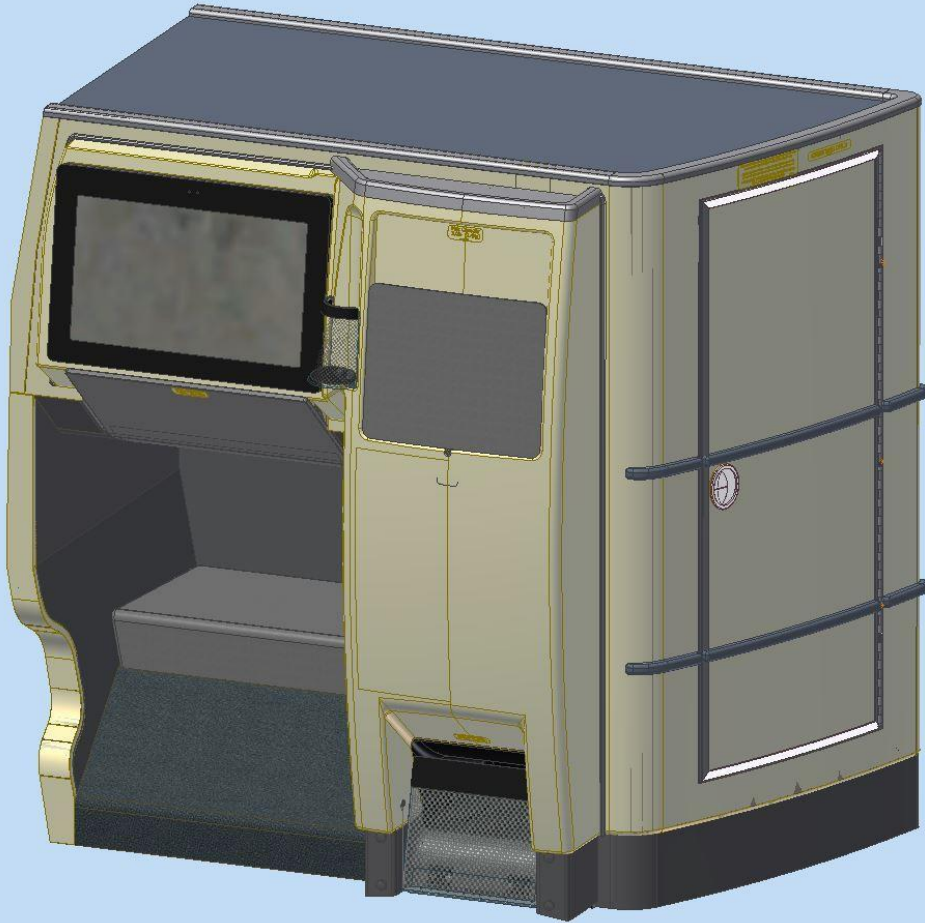

New Builds

Boeing B767 front row ottoman units / interface with first class seats; full design & EASA certification achieved



Our commitment to excellence is underscored by our approvals, a testament to our unwavering dedication to quality and safety.



New Builds

Airbus A330 VT19 front row monuments

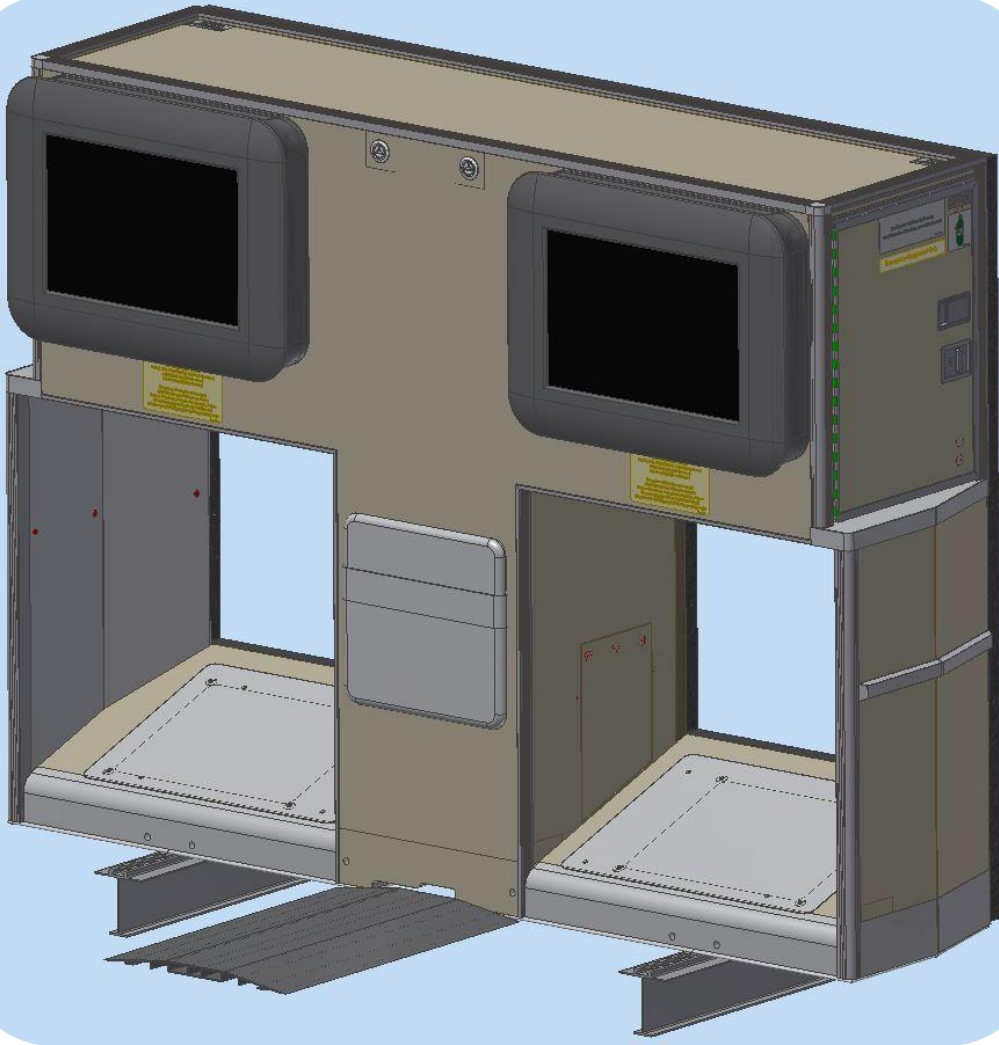

2.1.1. LC01: 9.0g Fwd

Patran 2010.2.3 64-Bit 03-Dec-15 16:09:20

Fringe: SC1.LC01:9.0G_FWD, A1:Static Subcase, Displacements, Translational, Magnitude, (NON-LAYERED)

Deform: SC1.LC01:9.0G_FWD, A1:Static Subcase, Displacements, Translational,

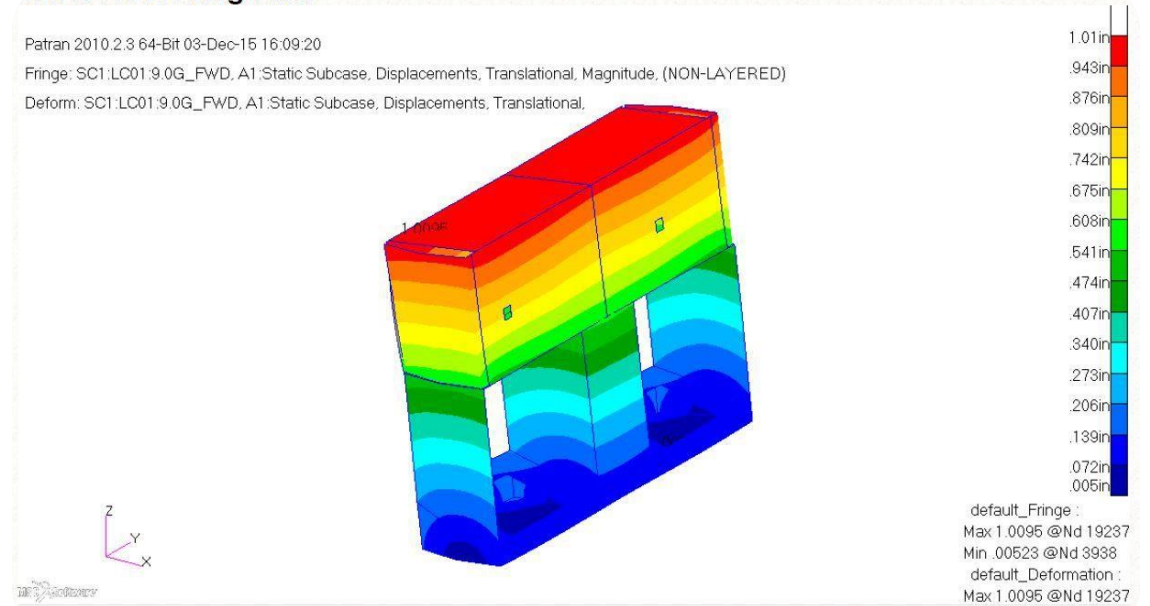

Figure 7 – LC01: 9.0g Forward Case [Maximum Deflection = 1.010in, 25.7mm]

New Builds

Airbus A330 VT19 front row monuments



New Builds

Airbus A330-200 full height stowage

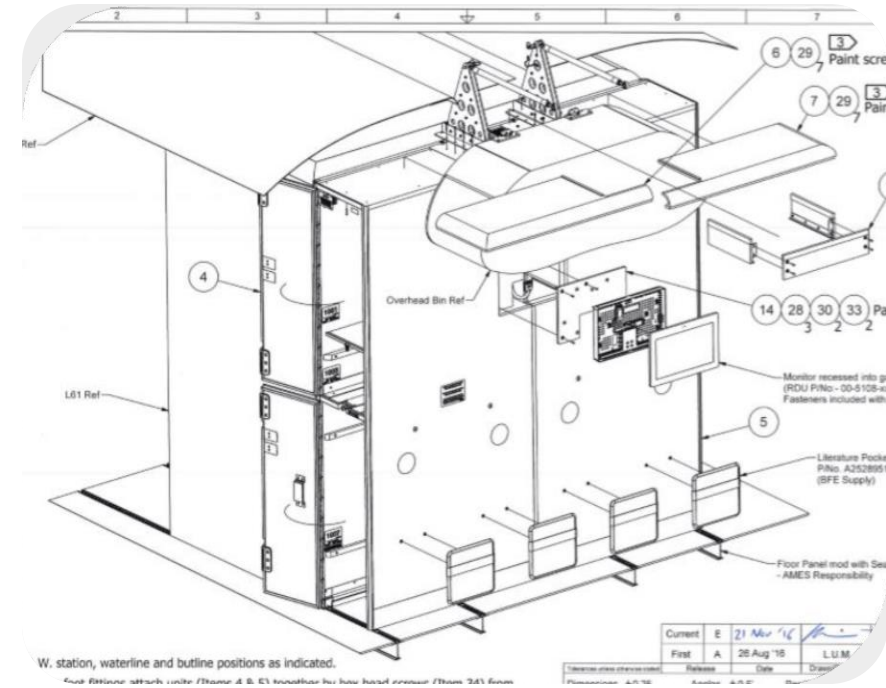

New Builds

First class composite seat binnacles designed and manufactured for TAS VT10, VT12 and VT15 programs

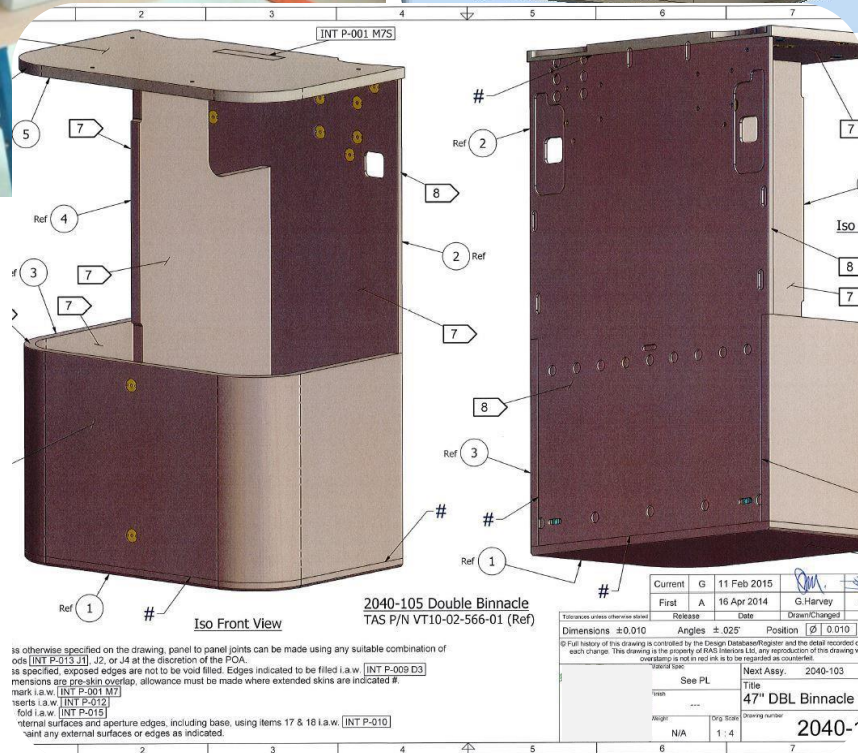
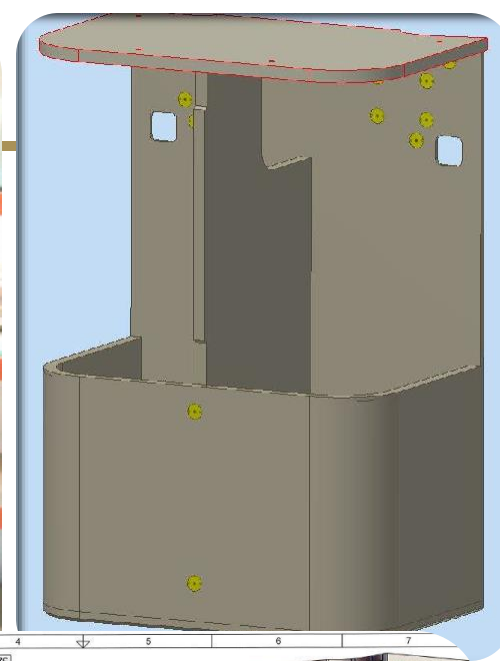

JETMS
COMPLETIONS

New Builds

Airbus narrow body pull-out dogbox/emergency equipment storage

From inception to flawless execution, every aspect is meticulously overseen, ensuring an unmatched level of sophistication in every design and construction project we undertake.

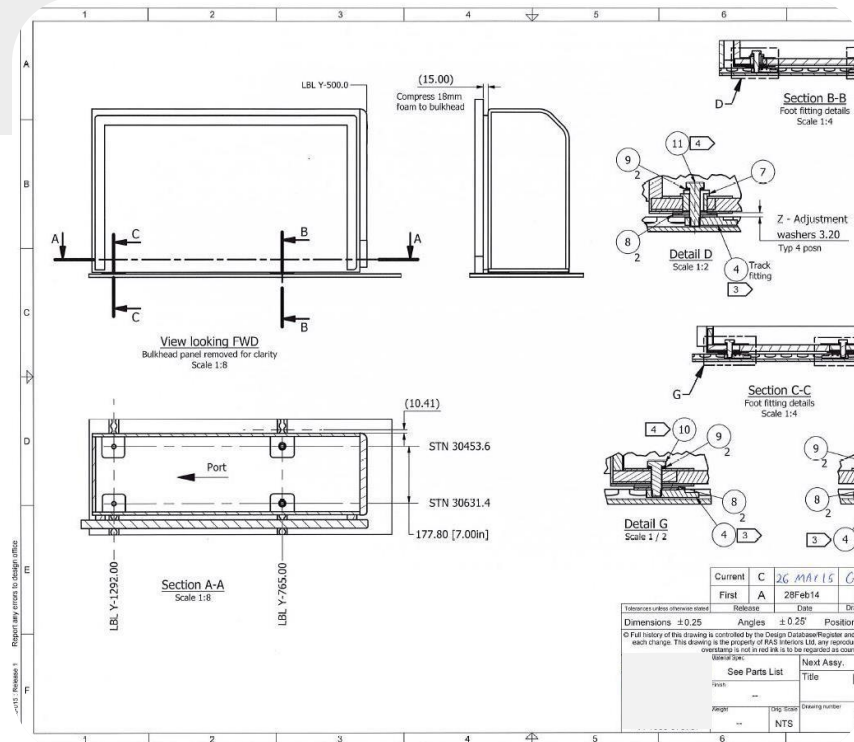
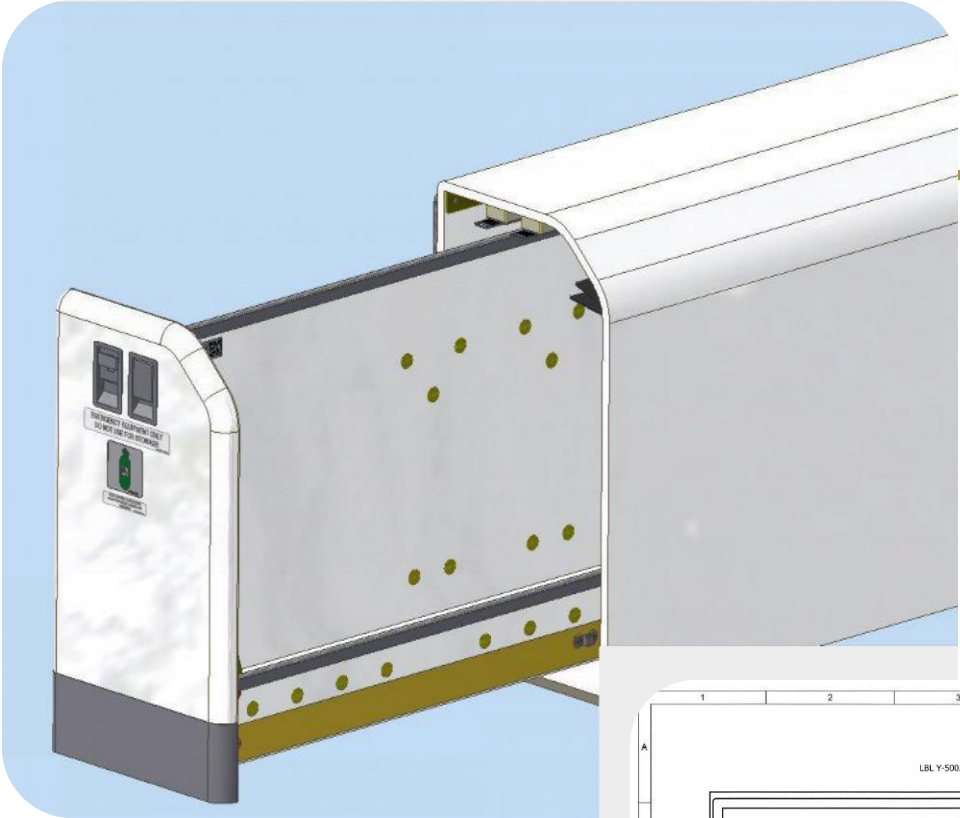

JETMS
COMPLETIONS

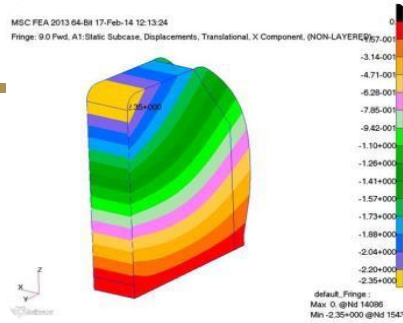
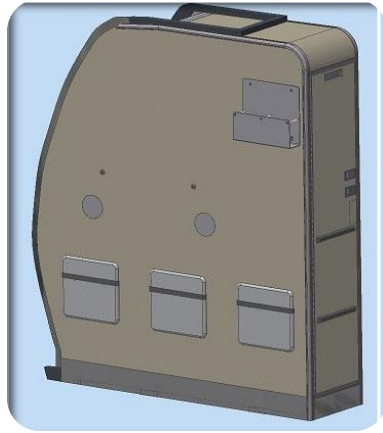
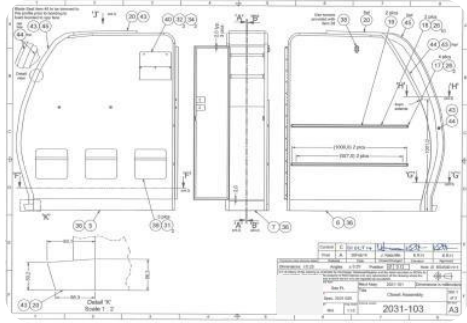

New Builds

Manufacture of Airbus A320 family forward closet/literature pockets custom colours to suit client's request



Our devoted team meticulously crafts aircraft interiors, seamlessly bringing concepts to life with unparalleled attention to detail.

New Builds

Manufacture of Airbus A320 family G2 galley unit

With a full spectrum of certifications, we assure you that every project is executed with precision and in compliance with the most stringent industry regulations.

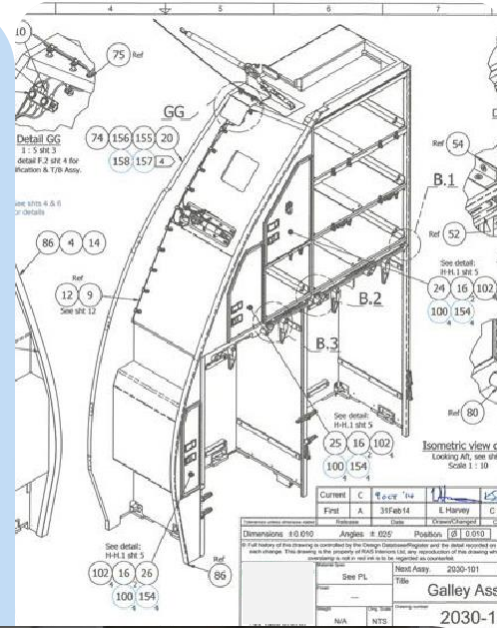

MSC FEA 2013 64-Bit 24-Feb-14 15:32:08
Fringe: 9.0 Fwd, A1: Static Subcase, Displacements, Translational, X Component, (NO

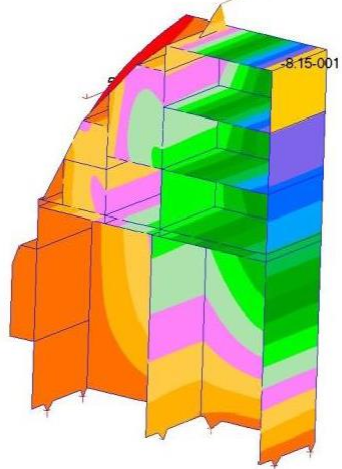

New Builds

Boeing 737-800 G2 galley

12 weeks from design kick-off to galley delivery. A Plug & Play solution for additional meal service storage, for exceptional service to your passengers on board.

The additional galley can be adapted to different aircraft types and installed without any additional changes to the existing cabin layout.



New Builds

Airbus A330 smoke bulkhead

Smoke bulkhead and door system for wide-body aircraft. A quick Plug & Play solution to convert a passenger aircraft into a cargo aircraft. Safety first, the smoke bulkhead creates a safety barrier between the payload and the crew. The system also provides protection against smoke and potential fire.

Available as a STC for all wide-body aircraft.

New Builds



Boeing 737 windbreak

New Builds

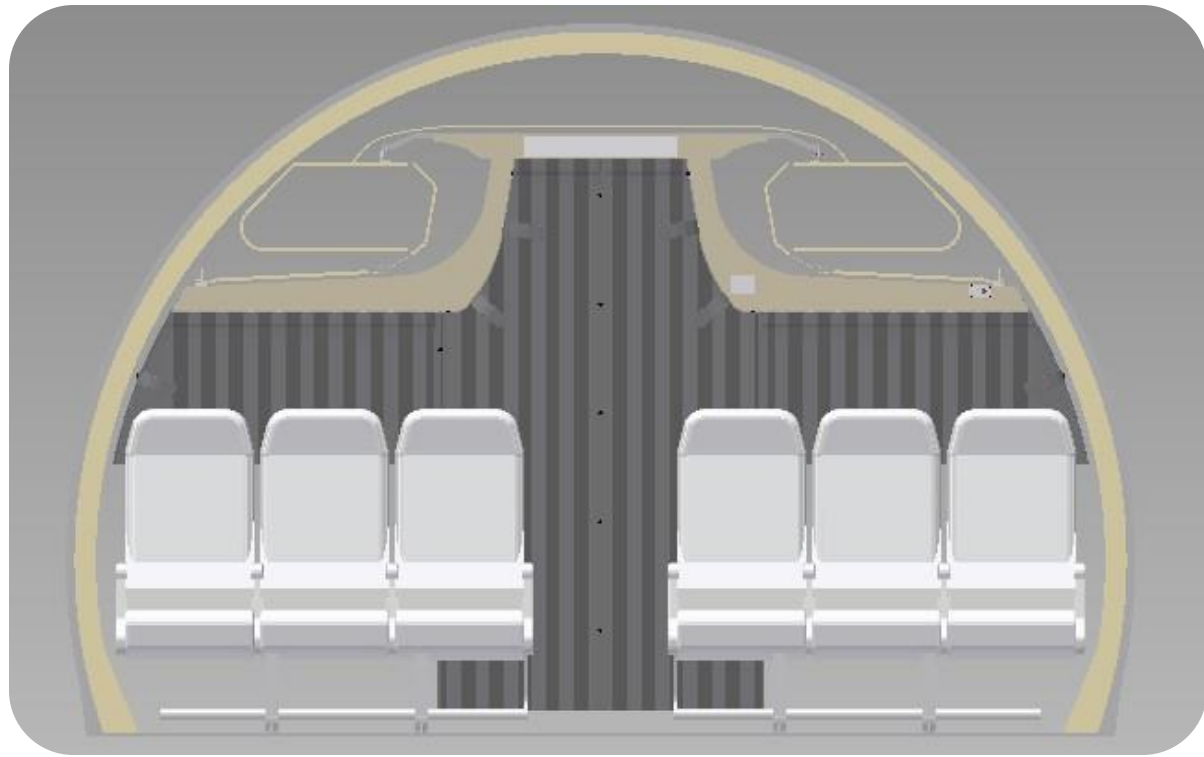

Boeing 737 curtain divider



New Builds

Manufacture of Embraer E190 storage units

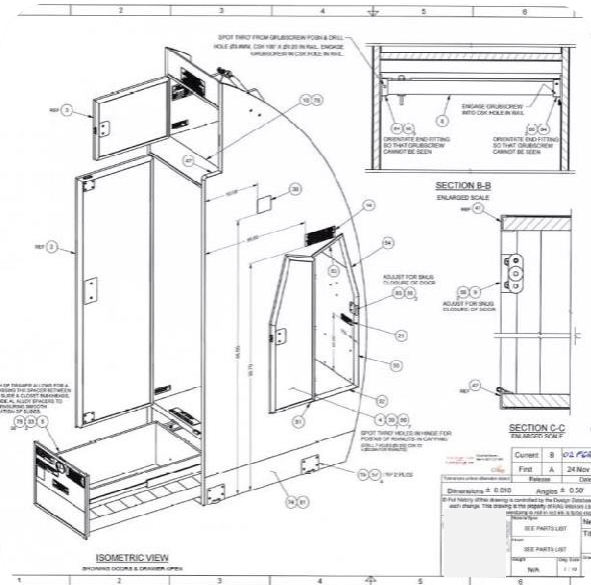
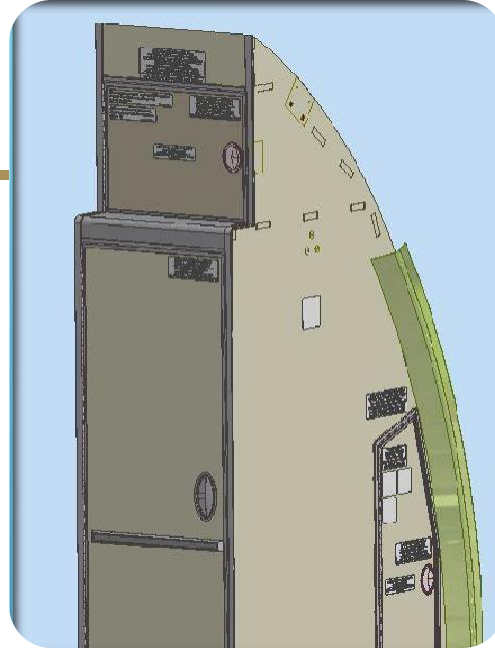

JETMS
COMPLETIONS

New Builds

Manufacture of AIRBUS A330 G10 galley unit

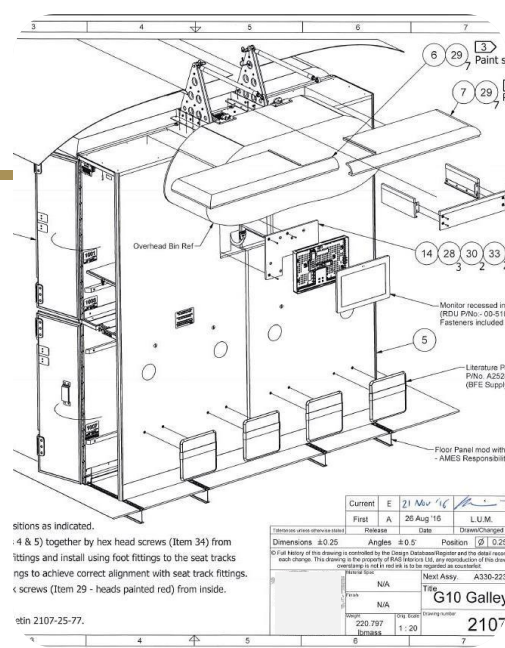

positions as indicated.
 4 & 5) together by hex head screws (Item 34) from fittings and install using foot fittings to the seat track fittings to achieve correct alignment with seat track fittings.
 6) screws (Item 29 - heads painted red) from inside.

Revision 1: 20

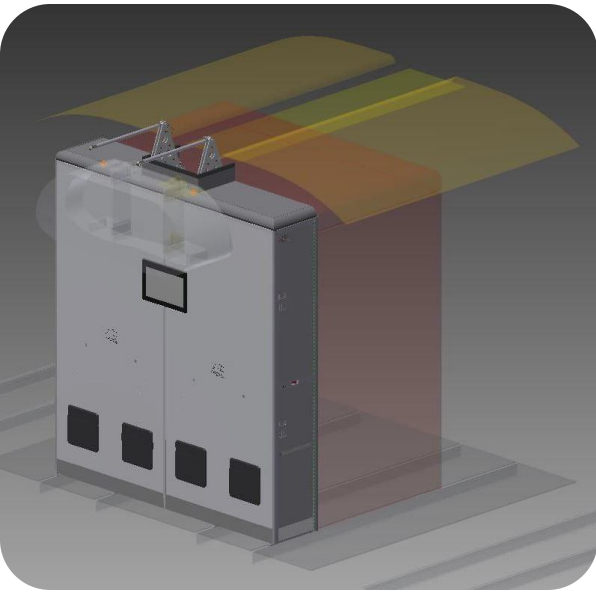

New Builds

A330 lavatory upgrade for major European airline

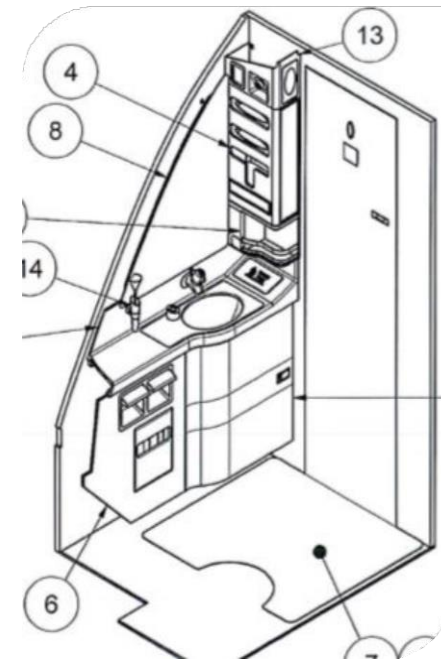
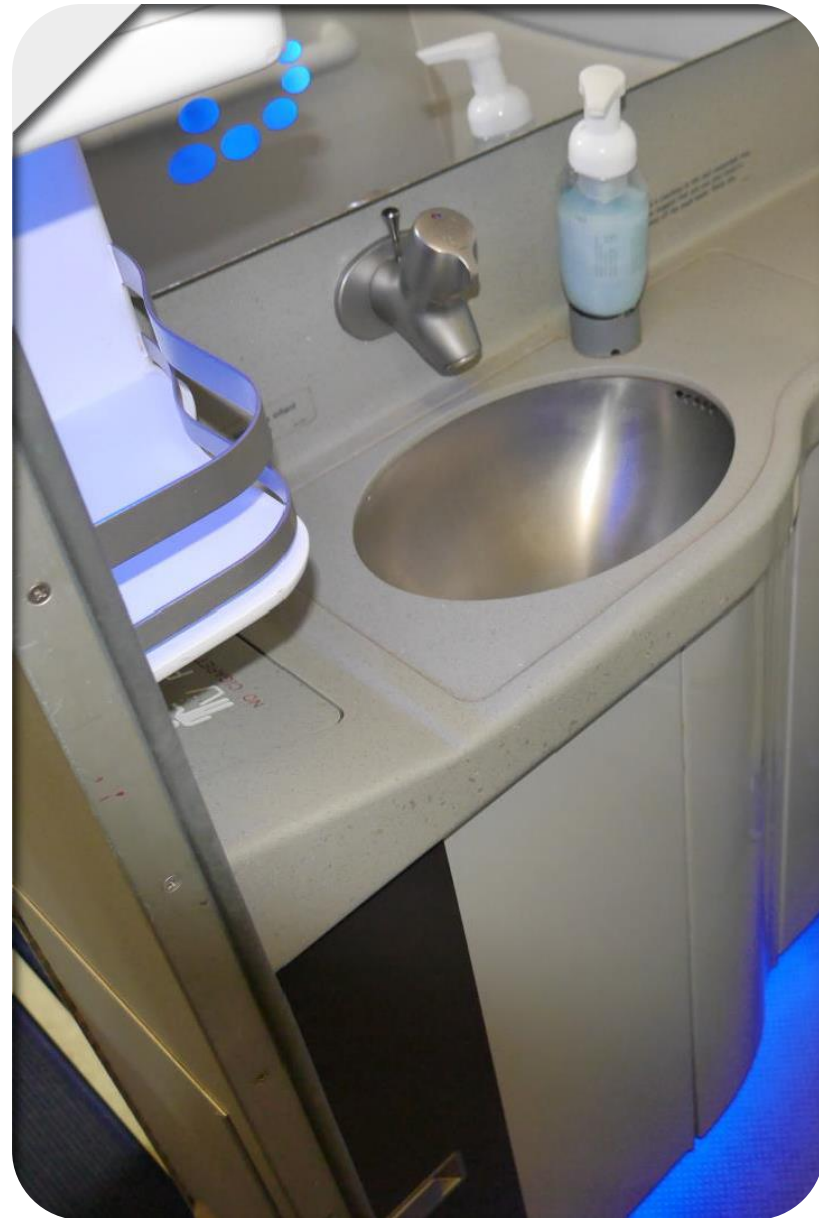

JETMS
COMPLETIONS

New Builds



Elevating crew comfort to new heights

Recognizing the crucial role that a well-rested crew plays in ensuring safe and efficient flight operations, we have crafted an oasis in the sky that seamlessly blends comfort, functionality, and simple, but comfortable design.



New Builds

Completed interior for Head of State
Voyager - AIRBUS A330

We offer a unique opportunity to create a full interior project for any type of aircraft, starting from a blank canvas.

Our seasoned team of designers and craftsmen specialize in transforming concepts into tangible, awe-inspiring realities. Whether it is a modern oasis in the sky or a classic masterpiece, we understand all preferences, lifestyle, and brand identity.



New Builds



Out-board ottoman unit



New Builds

Centre ottoman unit drawing design and 3D CAD model

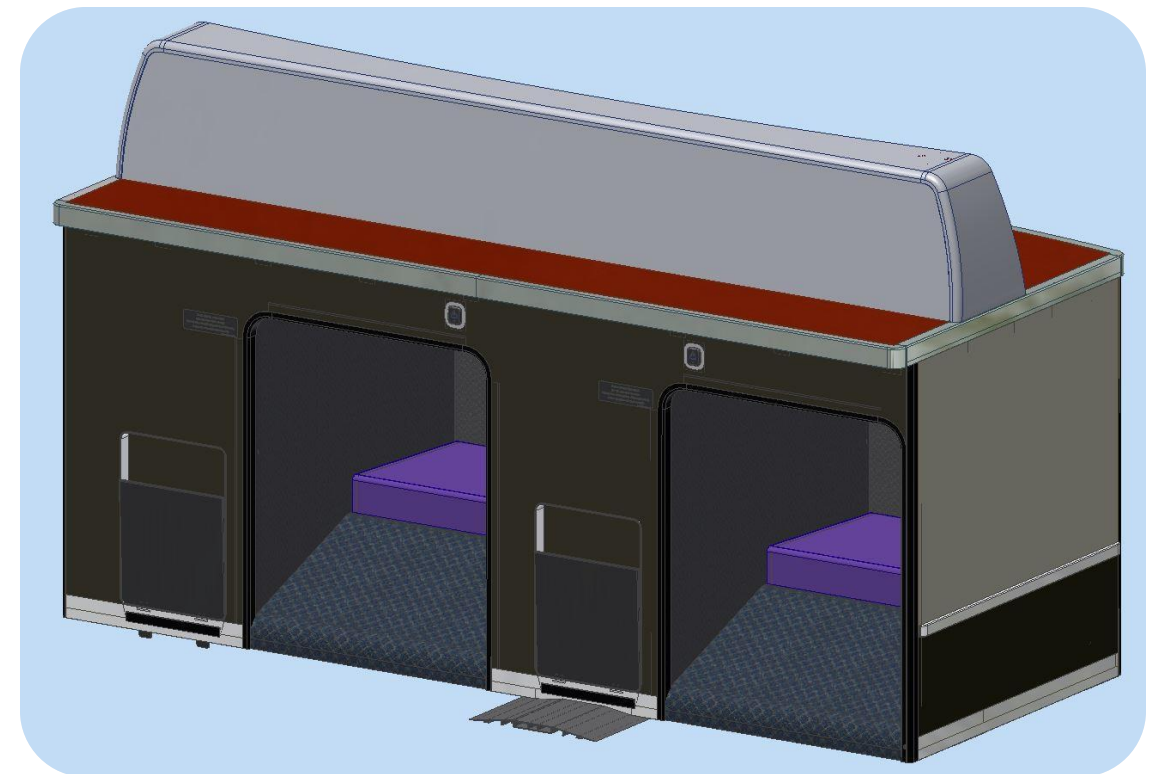
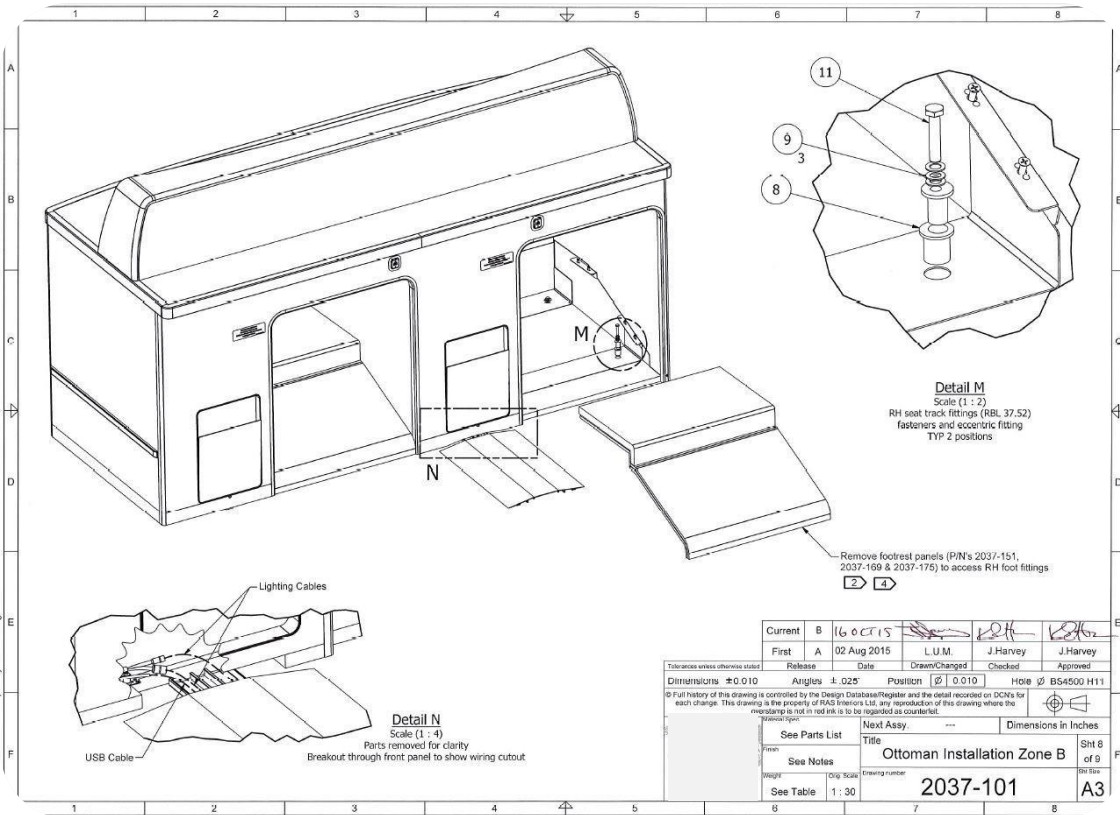

New Builds

Centre ottoman unit



Front



Back

New Builds

Changing room 3D wire frame isometric

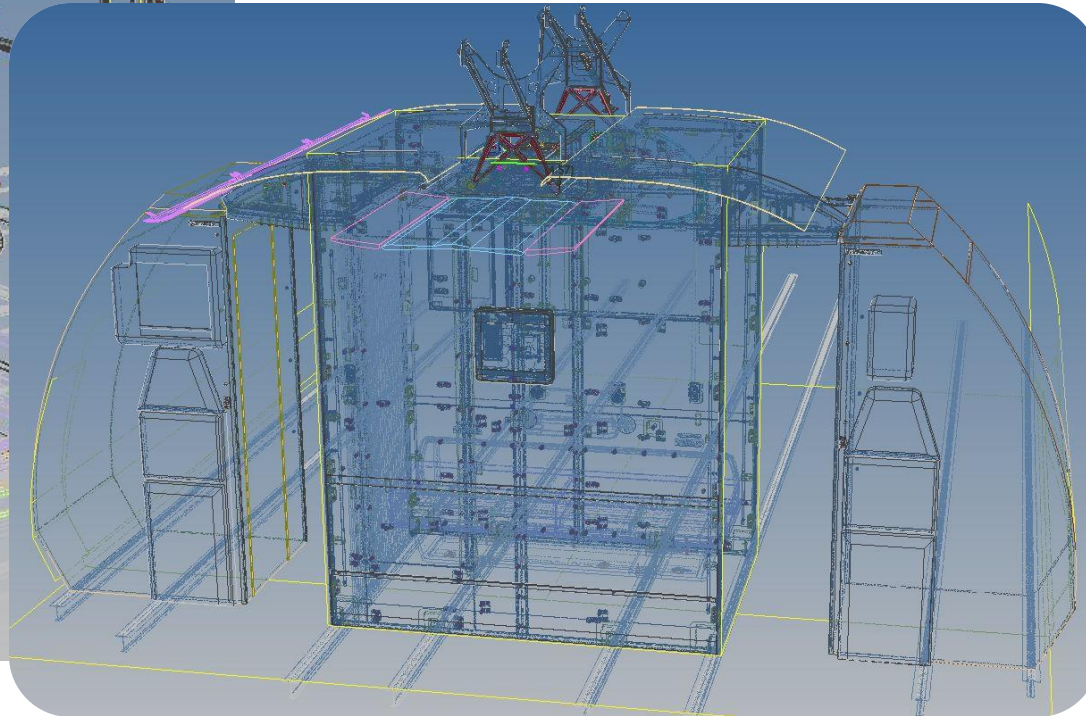
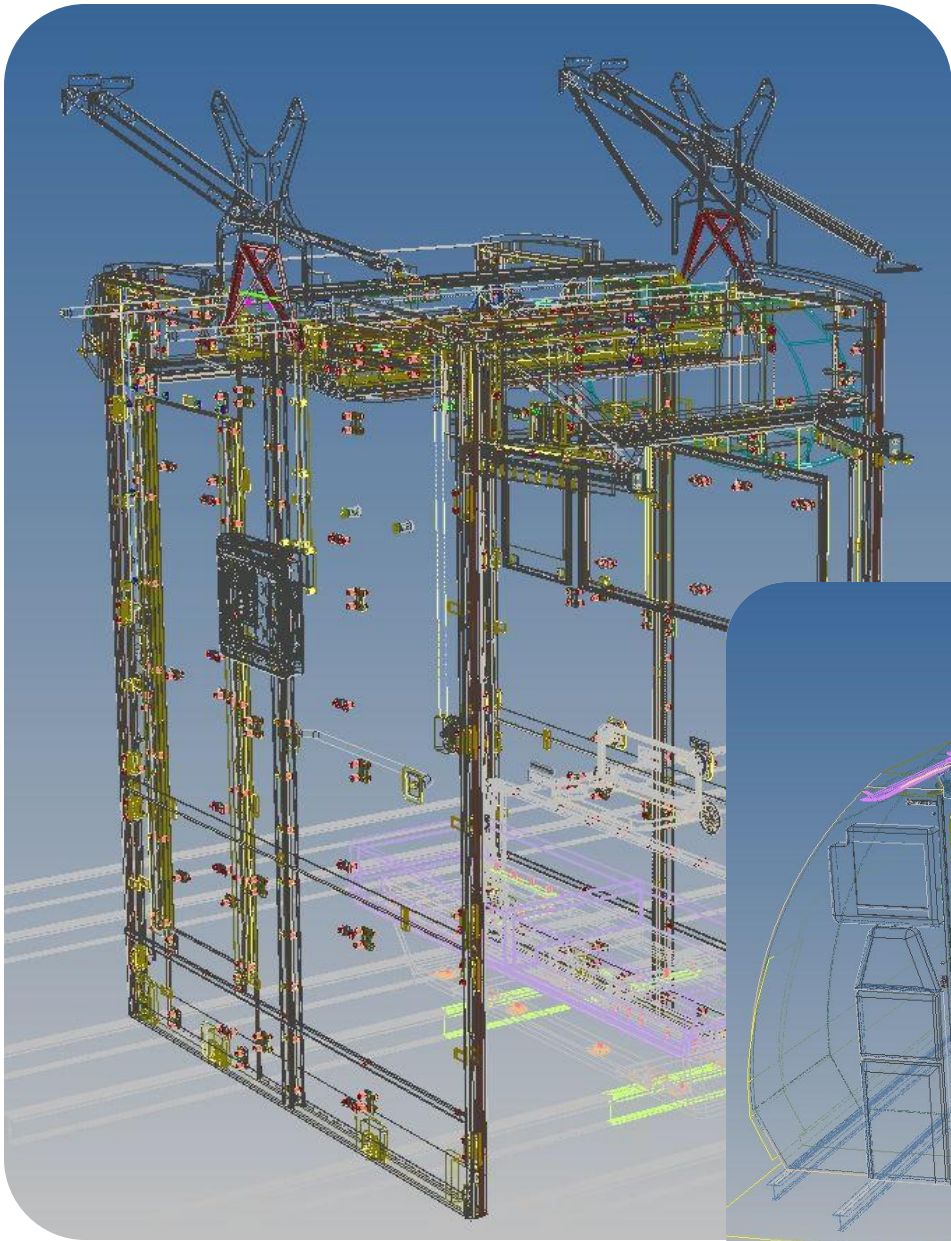

JETMS
COMPLETIONS

New Builds

Changing room 3D CAD Model

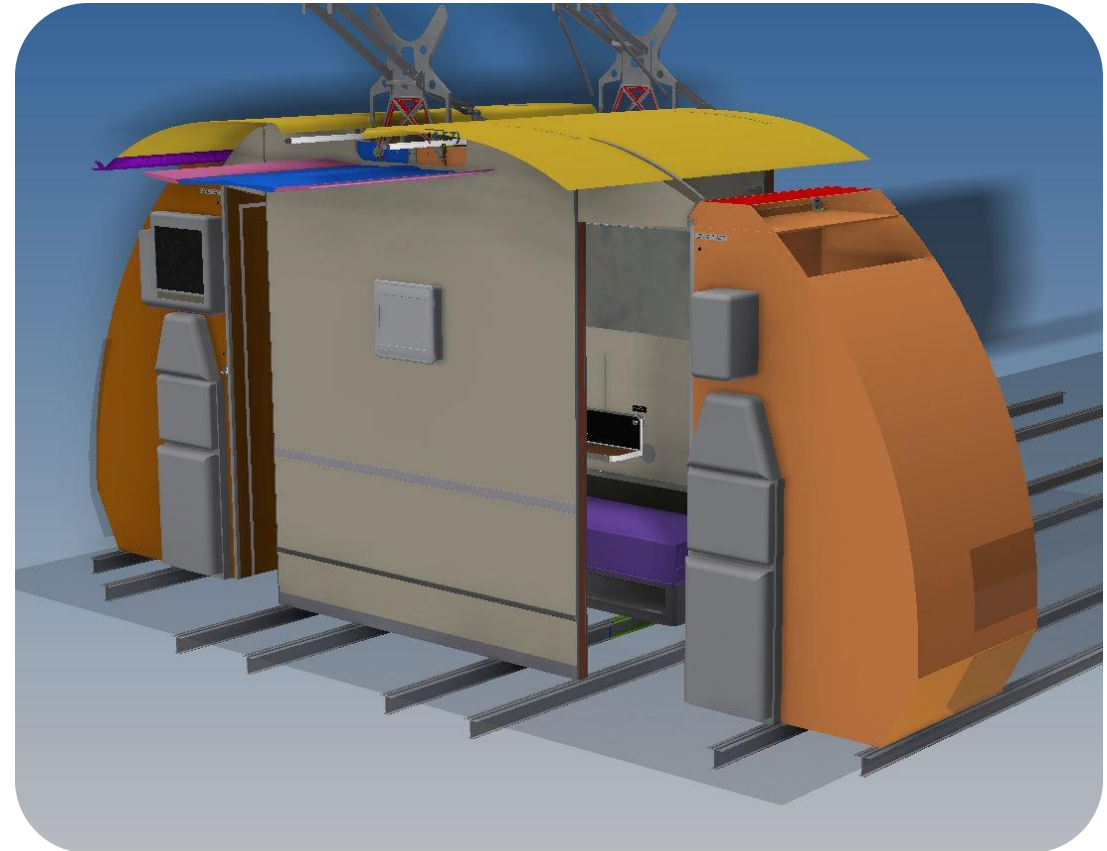
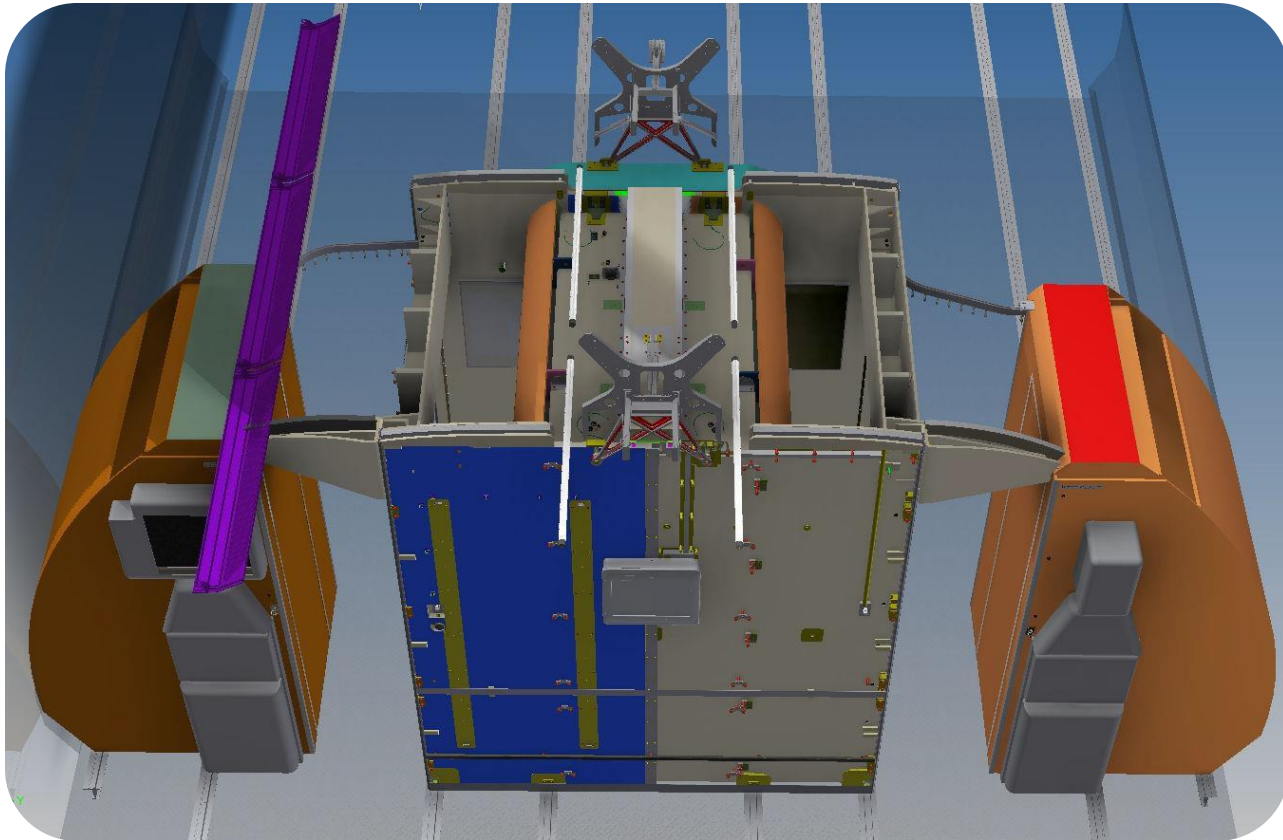

New Builds

Changing room 3D CAD Model

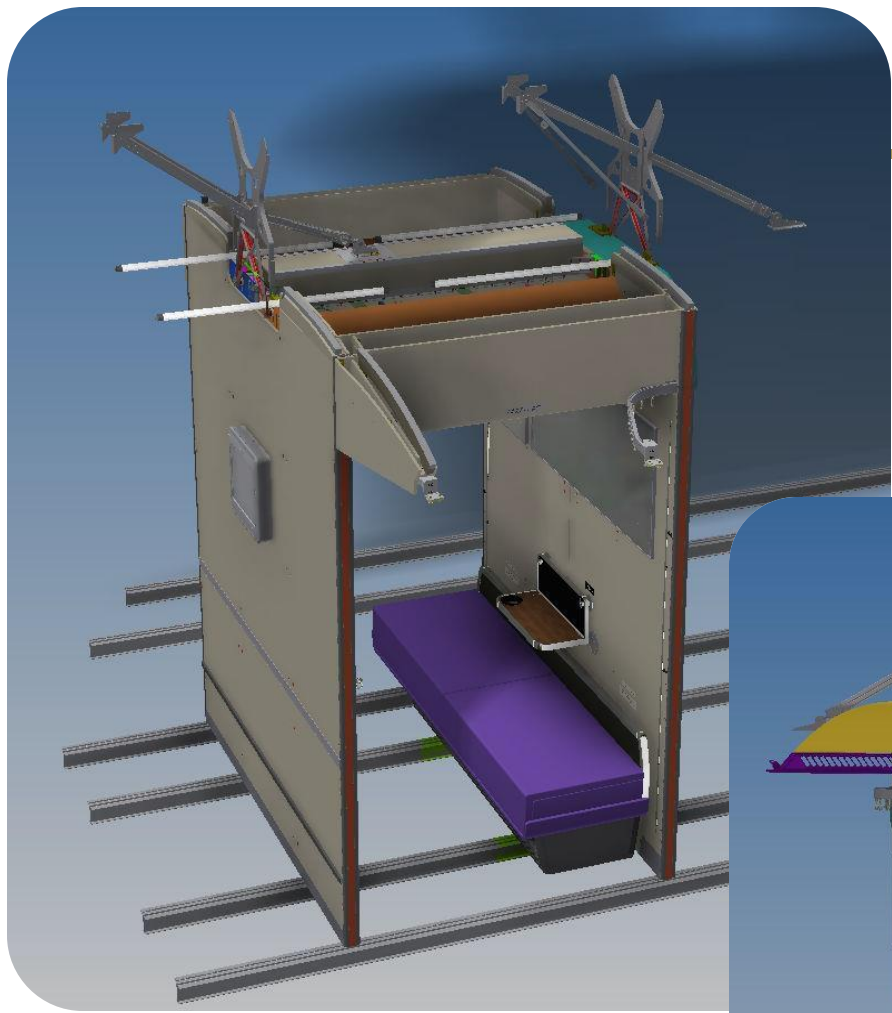

New Builds



Changing room mock-up

New Builds

Display arrays for the helicopter

Transforming concepts into reality is our forte, particularly when it comes to aircraft of all types. Your vision takes flight with our expertise, bringing innovation and precision to every design.

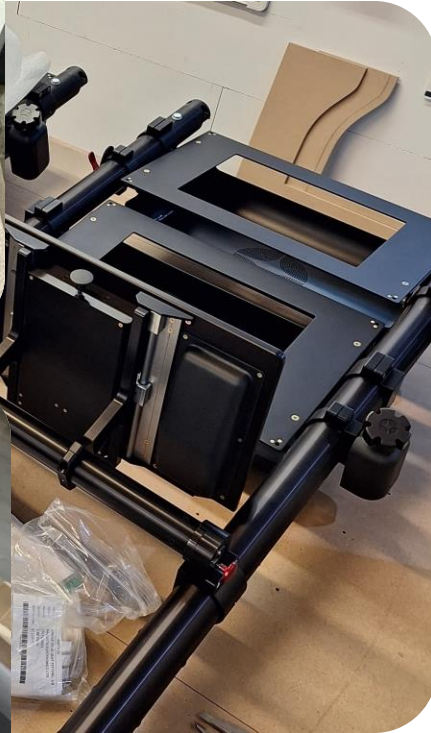

New Builds

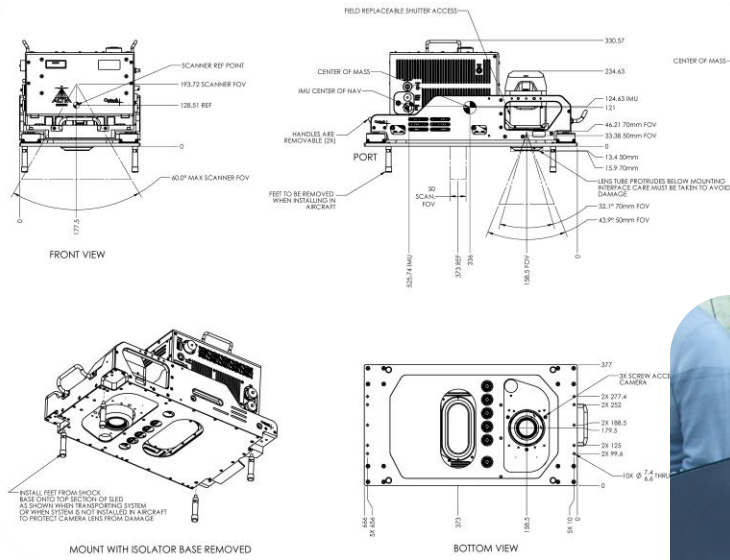

Robinson camera mount



New Builds

HELI-ONE Super Puma side ledge and pull-out table



New Builds

SPECIAL orders

Elevating aircraft experience with bespoke special orders, where meticulous attention to detail meets innovation. Imagine custom-made metal plates seamlessly integrated into your aircraft's interior, showcasing both functionality and aesthetics. Our tailor-made drawer inserts not only optimize storage but also reflect a distinct style. These personalized touches redefine luxury in aviation, making every journey a testament to exclusivity and sophistication.



REFURBISHMENT



Refurbishment

Breathing new life into timeless pieces



Our services include any type of repairs for any major defects that may arise on the surface of the aircraft and its interior details during its operational lifespan.



Refurbishment

Breathing new life into timeless pieces



Whether it's intricate woodwork or cutting-edge materials, our team's proficiency extends across the spectrum, ensuring that each refurbishment project is handled with precision and excellence.



Refurbishment

Seats & soft trim

With our fully equipped trim shop we are able to offer complete soft trim services including :

- Re-covering cabin seats including interior panels
- Re-covering crew seating
- Re-styling seats & divans
- Re-foaming seats & divans
- Cleaning



SPECIAL SERVICES



Special Services

Leather, particularly on seats is subject to wear and discolouration, this repair reinstates the original colour by use of a colonisation coat colour matched to the original material finish.

This disposition is compiled to show that the colonisation of leathers meets the requirements of CS25 & CS29 for all aircraft & rotorcraft with 19 seats or less, which allows us to release the components with a Form 1.

Leather colonisation – approved process



Special Services



TEXTILE FLOORING

Carpet & NFT services

We are able to offer a complete aircraft cabin flooring renewal and repair service.



NON-TEXTILE
FLOORING (NTF)

Special Services

Minor repair approval

Our minor repair approval covers repairs to cabin interior furnishing within the cabin interior of aircraft like Airbus, Boeing, Bombardier, Cessna, Dassault, Embraer, Gulfstream and more. The minor repairs are done in-situ and released with a Form 1.

Special Services

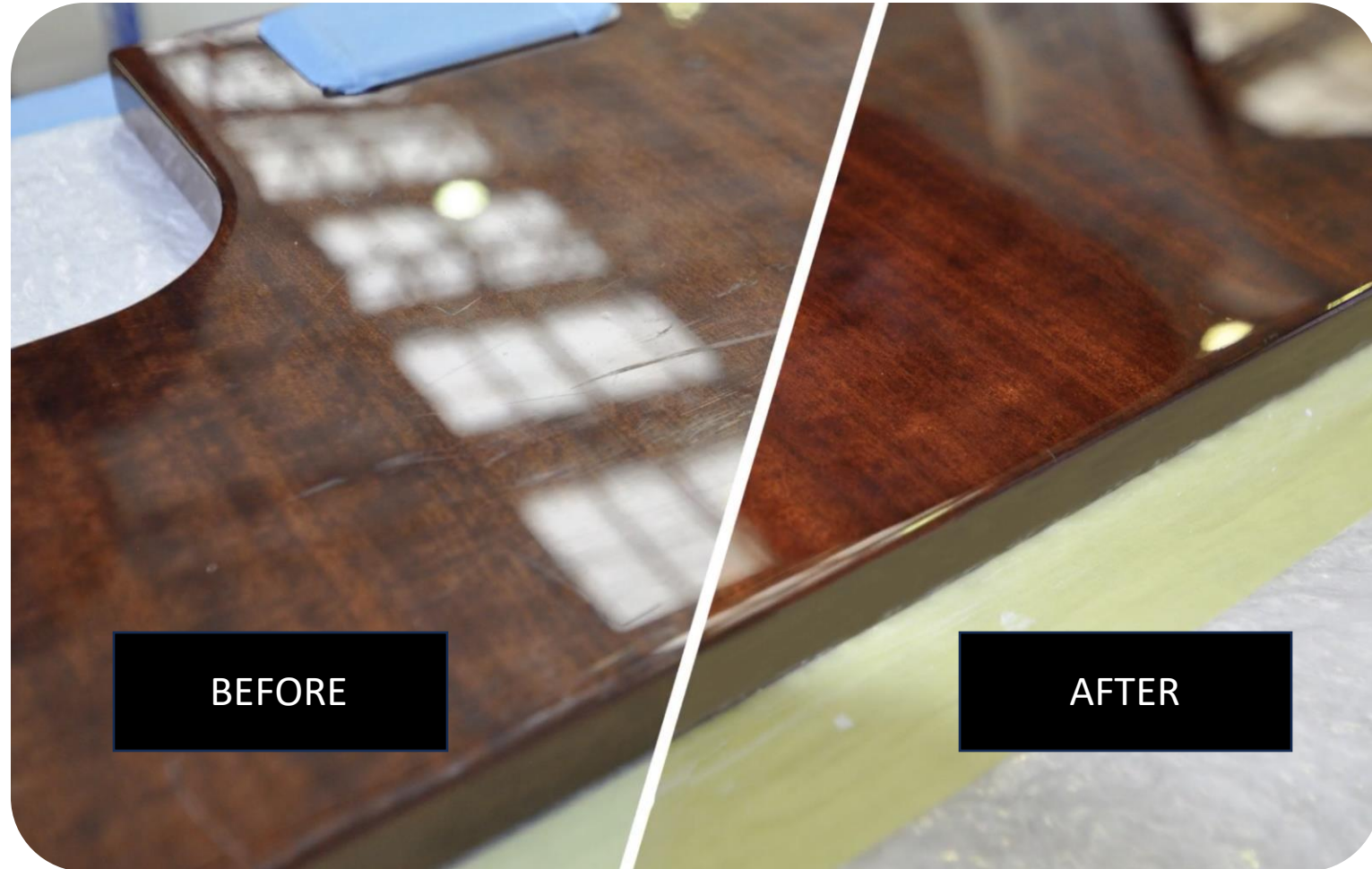

Minor repair approval

Through our precision-focused approach, we breathe new life into your aircraft's interior, unveiling a refreshed and flawless appearance.

From the deepest understanding of all issues to the perfect perfection at the end.

Special Services

VARÃO DE CABIDES
PESO MÁXIMO PERMITIDO
13KG

COAT ROD
MAXIMUM WEIGHT ALLOWANCE
30LBS (13 KG)



Interior & exterior placard services

We can produce interior and exterior placards to exact specifications. If required, we can modify placards to accommodate any languages that may be needed for any particular aircraft.

Release with a Minor MOD and Form 1.

The image shows the interior of a private jet cabin. The seats are upholstered in white leather and are arranged in a 2-2 configuration. The cabin has a modern, minimalist design with a light-colored interior. A yellow text overlay is positioned on the left side of the image. The cabin is well-lit, and the overall atmosphere is clean and professional.

SOME OF OUR INTERIOR
DESIGN PROJECTS









JETMS Completions Ltd

Bldg 510 Churchill Way London
Biggin Hill Westerham England TN16
3BN

+44 (0) 1959 576 747

info.completions@jetms.aero

