



PRECISE.  
PASSIONATE.  
UNITED.

## AT A GLANCE



Boasting a remarkable workforce of over 11,500+ skilled professionals and operating across 17 diverse business lines, the Avia Solutions Group generates an impressive annual revenue surpassing the \$2 billion mark. Moreover, Avia Solutions Group is the world's largest ACMI provider, with a fleet of 192 aircraft.

With an illustrious three-decade history, JETMS Completions stands as a preeminent force within the industry, specializing in crafting exquisite aircraft interiors for both commercial and VVIP aircraft. As an integral member of the esteemed Avia Solutions Group, alongside other esteemed JETMS brand companies, we proudly contribute to a dominant leadership position in the aviation industry.

At JETMS Completions, we leverage cutting-edge technologies and possess state-of-the-art manufacturing capabilities. Our unwavering commitment to excellence is further strengthened through our strategic alliance with JetMS Interiors in Kaunas, Lithuania.

Recognized as an EASA Part 145, CAA Part 21J, CAA Part 21G, and 145 approved organization, JETMS Completions continues to solidify its standing as a revered manufacturer of commercial aviation interiors. Notably, our leadership position in refurbishment services in the UK remains unparalleled.

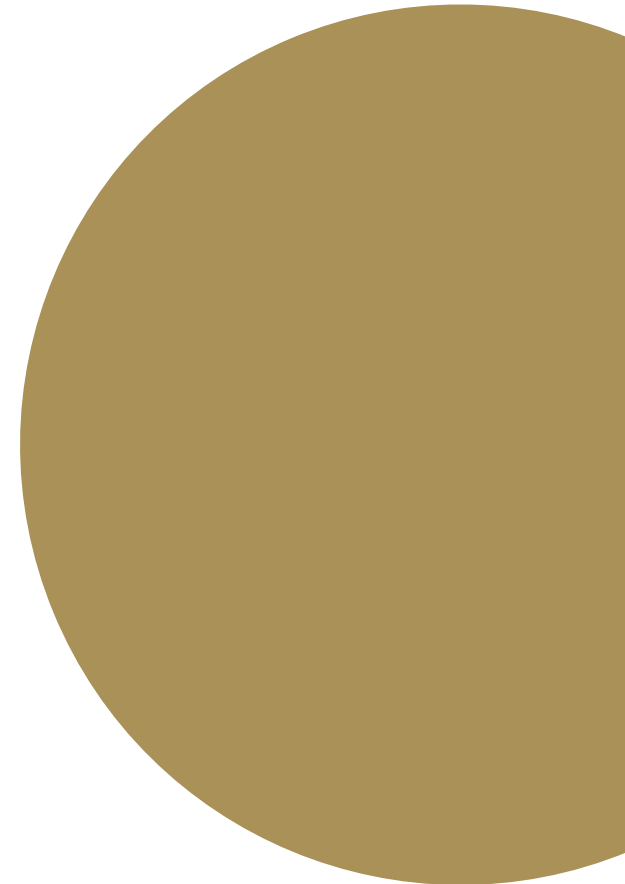

OPERATING IN TWO MODERN HANGARS



**6000 SQ M, BUILDING 510  
IN LONDON, UK**



**7000 SQ M HANGAR  
IN KAUNAS, LITHUANIA**

WE ARE CERTIFIED

- ✦ **EASA** Part-145
- ✦ **CAA** UK Part-21J
- ✦ **CAA** UK Part-145
- ✦ **ISO** 9001:2015
- ✦ **CAA** UK Part-21G
- ✦ **ASA**-100

DESIGN & PRODUCTION CAPABILITIES

Design and Production (of cargo and passenger aircraft cabin interior components)

Engineering Modifications

Other in-house engineering services and customized solutions

LIST



CNC router | model BPF 2141



CNC mill | model VF-2SSYT-EU



CNC lathe | model ST-20Y-NGC



Guillotine | model iSHEAR-B06-3100



Press brake | model iBLEND 3100

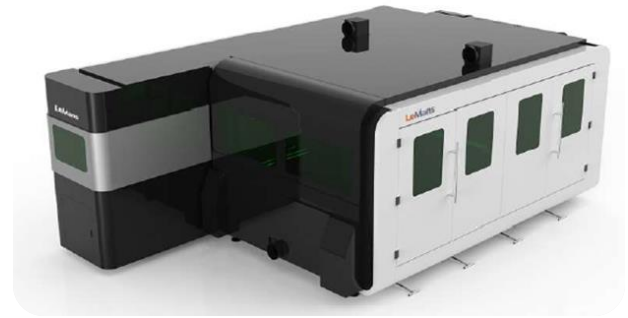

Laser | model LM4022GFplus



## FULL SPECTRUM OF SERVICES:

- NEW BUILDS
- REFURBISHMENT
- SPECIAL SERVICES
- SOME OF OUR INTERIOR DESIGN PROJECTS

# New Builds

Boeing B767 front row ottoman units / interface with first class seats; full design & EASA certification achieved

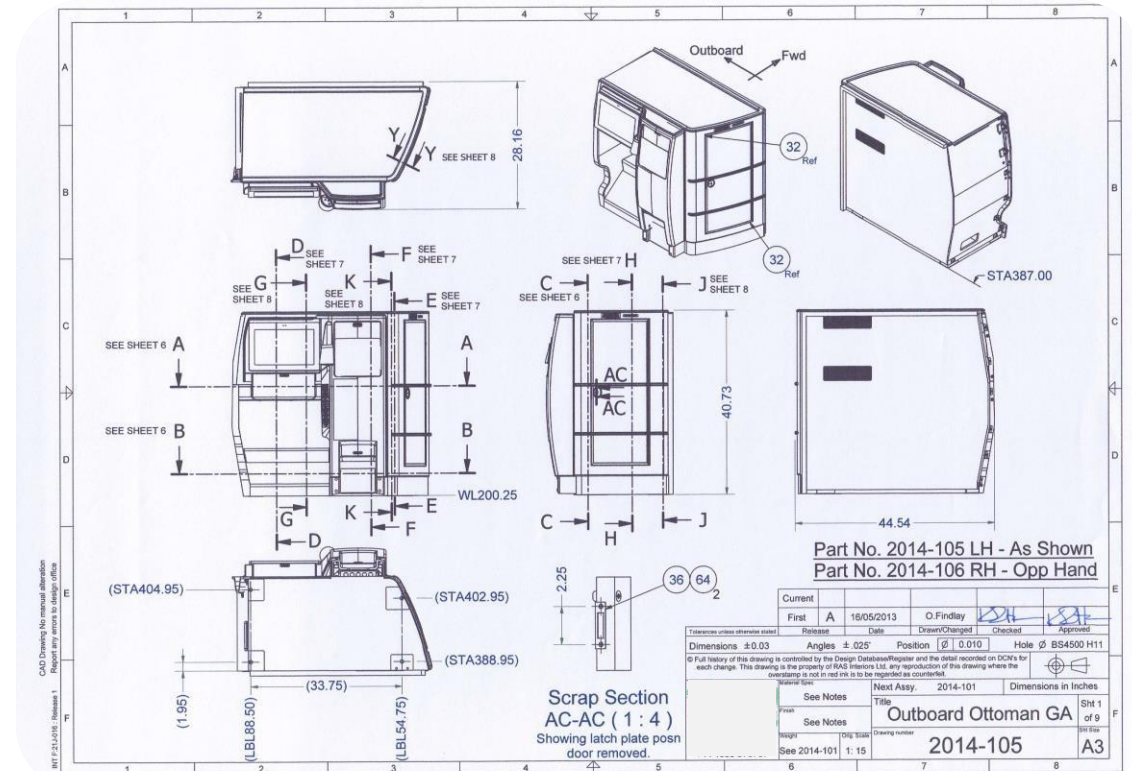
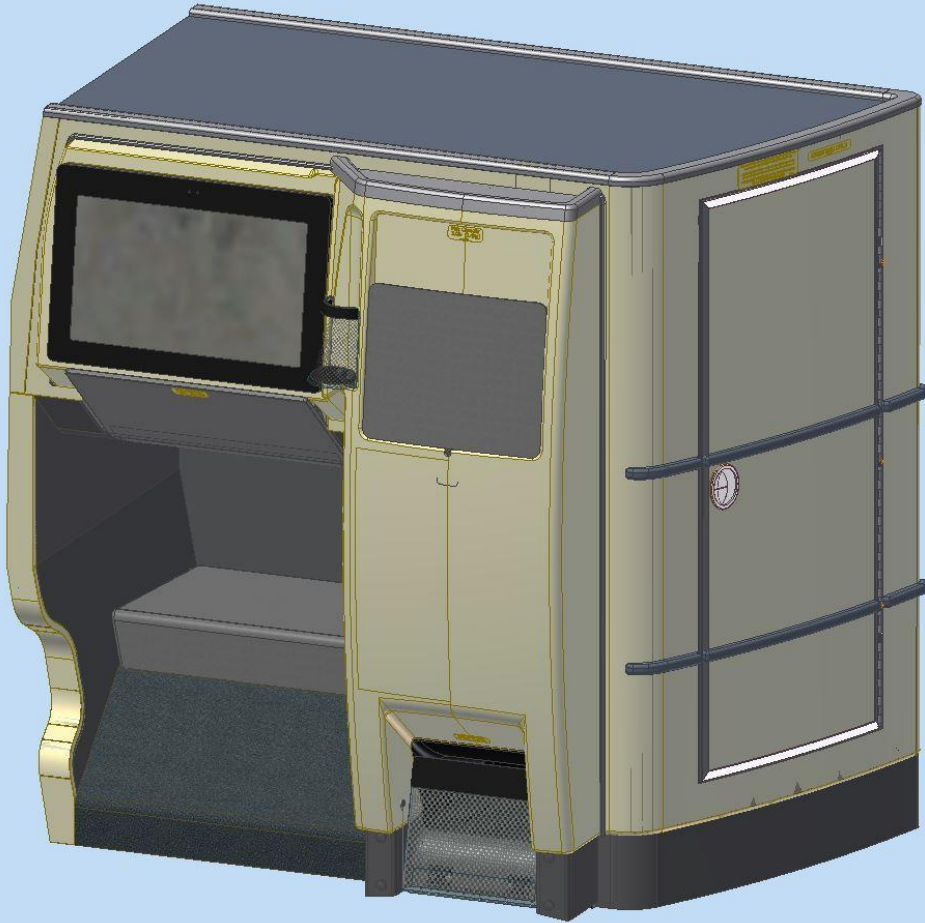

# New Builds

Boeing B767 front row ottoman units / interface with first class seats; full design & EASA certification achieved



Our commitment to excellence is underscored by our approvals, a testament to our unwavering dedication to quality and safety.



# New Builds

Airbus A330 VT19 front row monuments

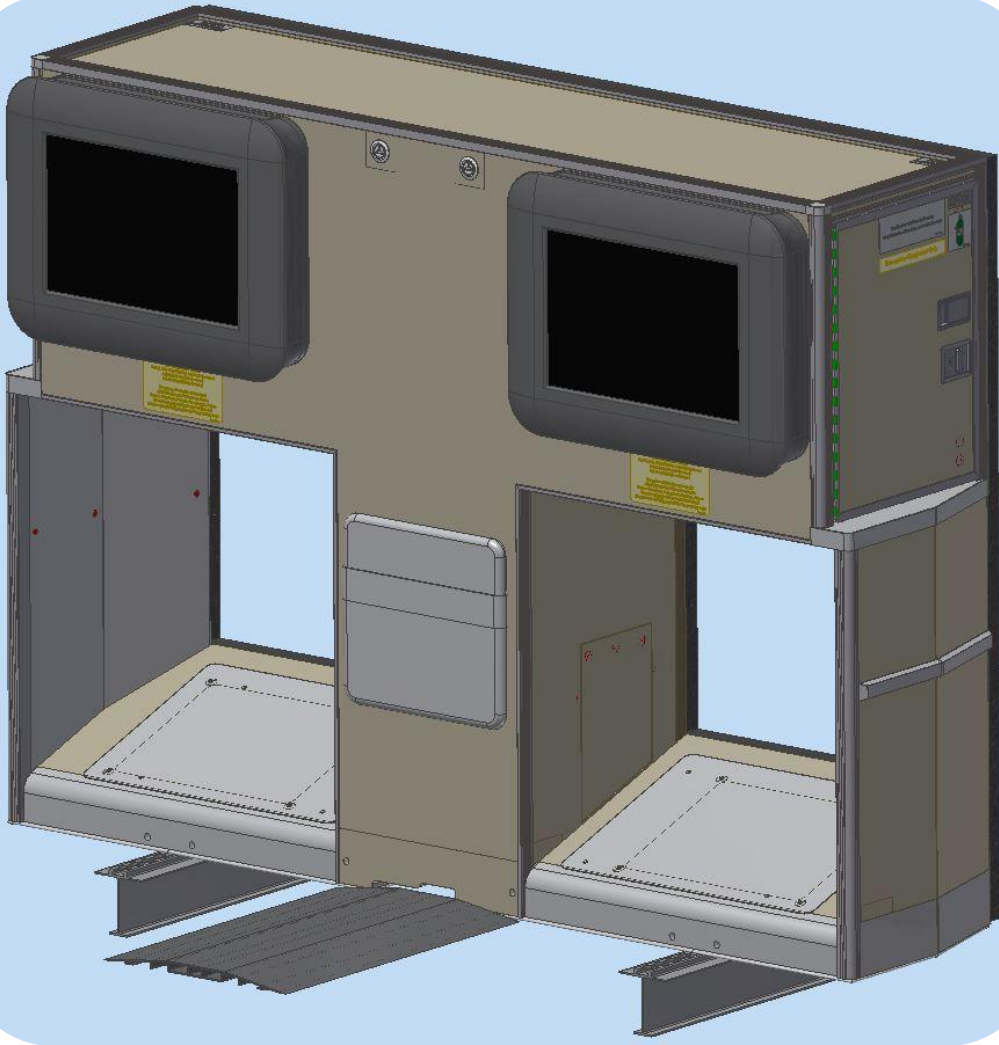

## 2.1.1. LC01: 9.0g Fwd

Patran 2010.2.3 64-Bit 03-Dec-15 16:09:20

Fringe: SC1.LC01:9.0G\_FWD, A1:Static Subcase, Displacements, Translational, Magnitude, (NON-LAYERED)

Deform: SC1.LC01:9.0G\_FWD, A1:Static Subcase, Displacements, Translational,

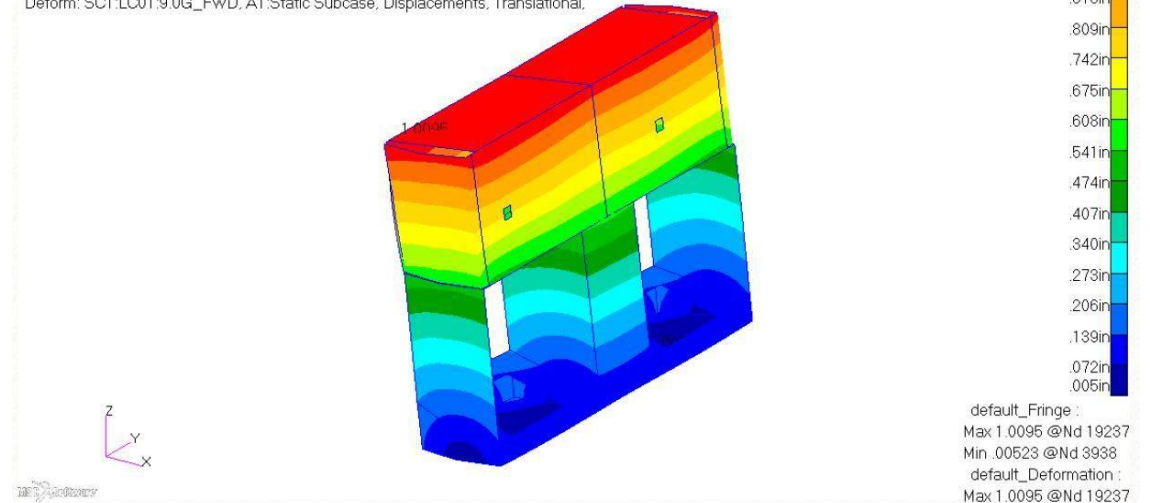

Figure 7 – LC01: 9.0g Forward Case [Maximum Deflection = 1.010in, 25.7mm]



# New Builds

Airbus A330 VT19 front row monuments



# New Builds

First class composite seat binnacles designed and manufactured for TAS VT10, VT12 and VT15 programs

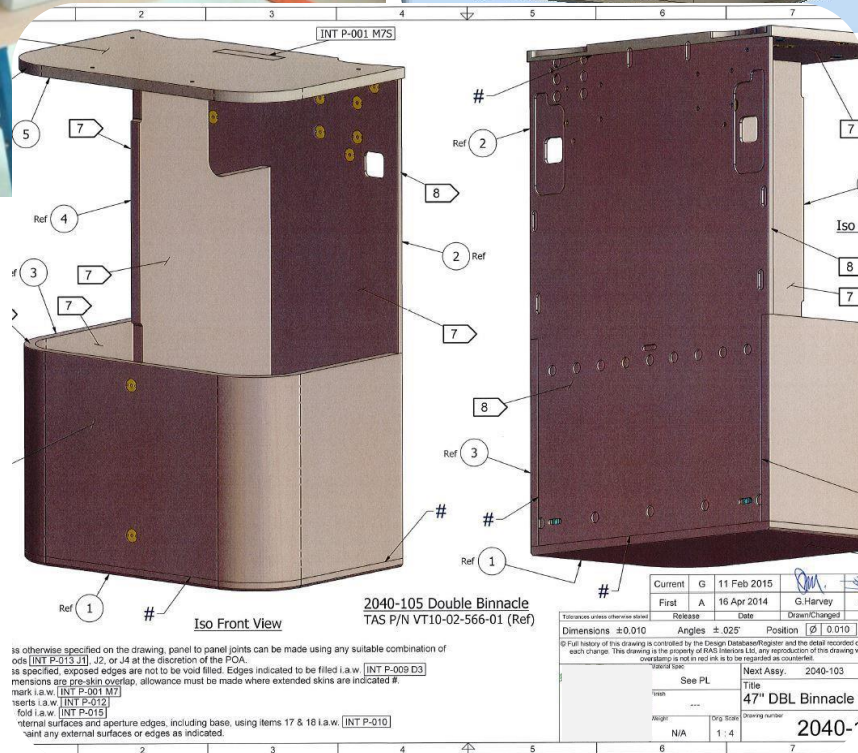
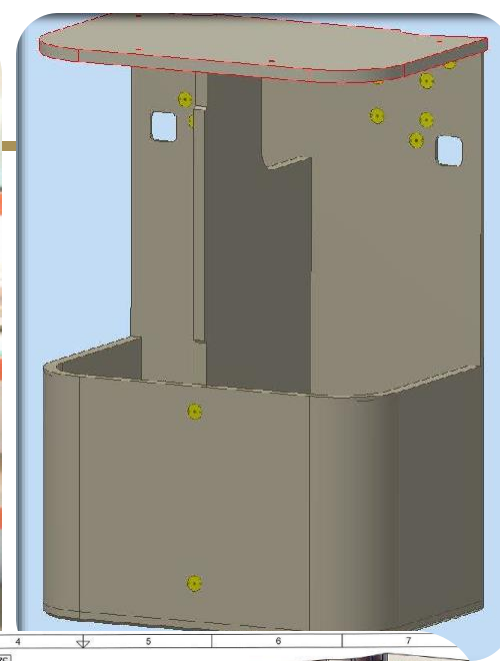

**JETMS**  
COMPLETIONS

# New Builds

Airbus narrow body pull-out dogbox/emergency equipment storage

From inception to flawless execution, every aspect is meticulously overseen, ensuring an unmatched level of sophistication in every design and construction project we undertake.

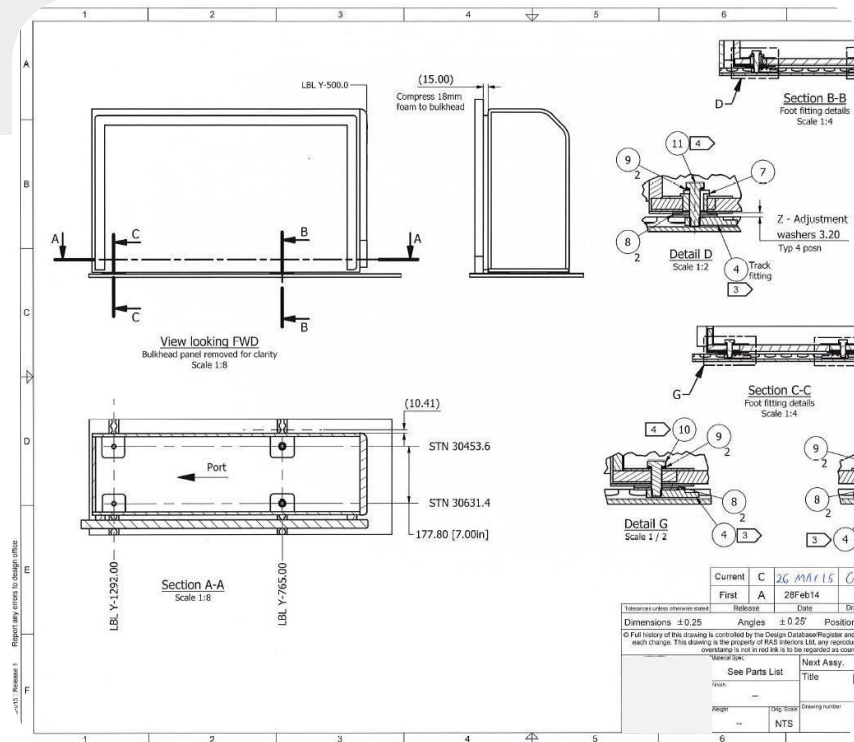
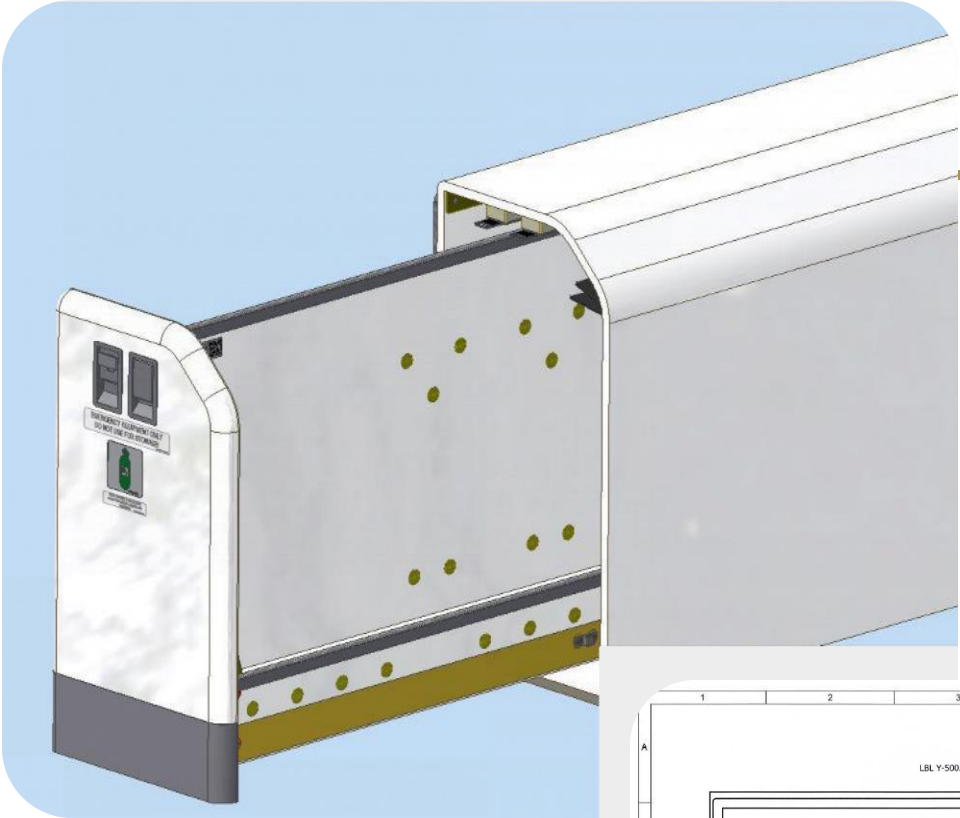

**JETMS**  
COMPLETIONS

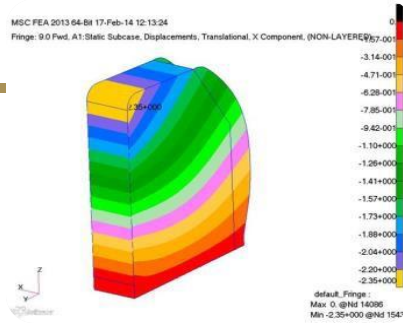
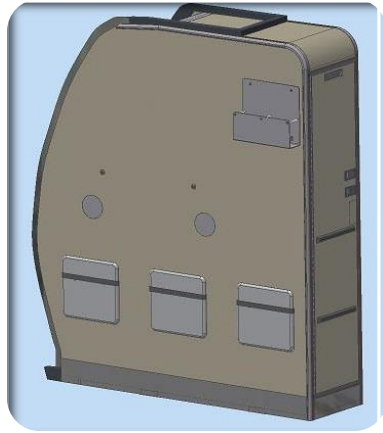
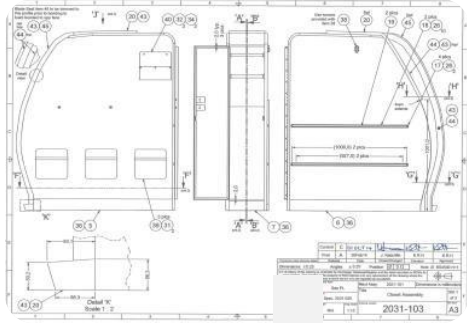

# New Builds

Manufacture of Airbus A320 family forward closet/literature pockets custom colours to suit client's request



Our devoted team meticulously crafts aircraft interiors, seamlessly bringing concepts to life with unparalleled attention to detail.

# New Builds

Manufacture of Airbus A320 family G2 galley unit

With a full spectrum of certifications, we assure you that every project is executed with precision and in compliance with the most stringent industry regulations.

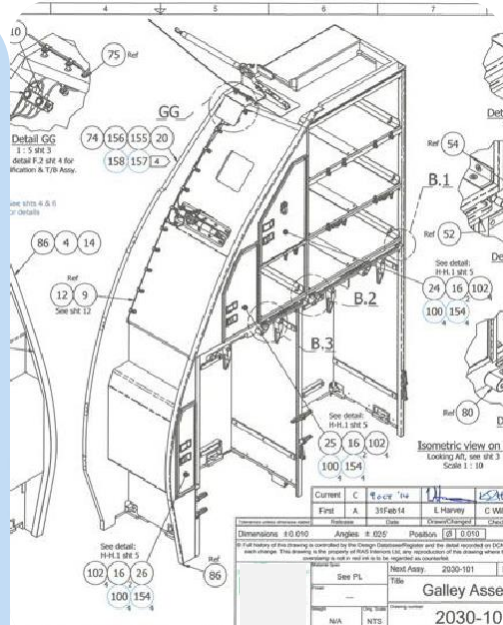
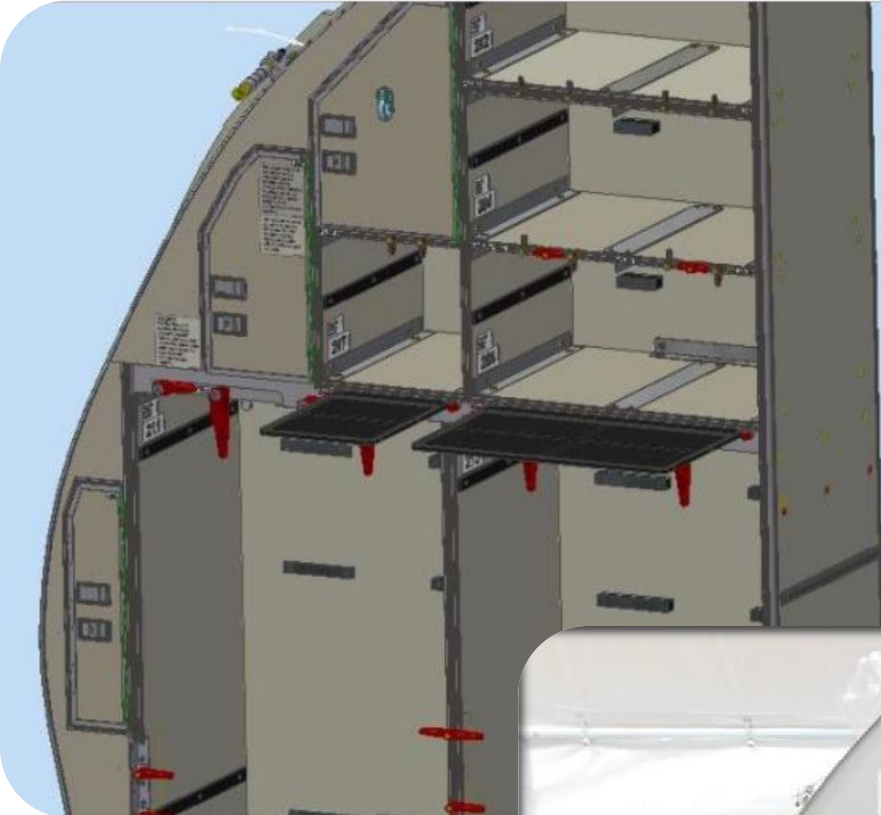

MSC FEA 2013 64-Bit 24-Feb-14 15:32:08  
Frige: 9.0 Fwd, A1: Static Subcase, Displacements, Translational, X Component, (NO

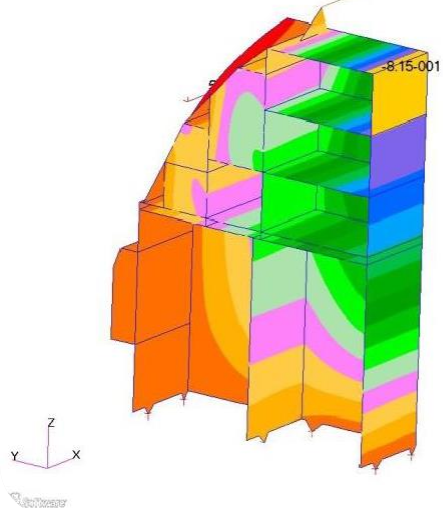

# New Builds

Manufacture of Embraer E190 storage units

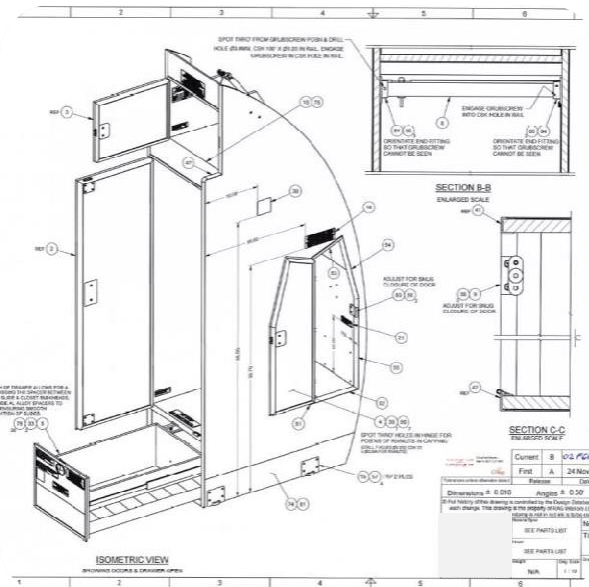
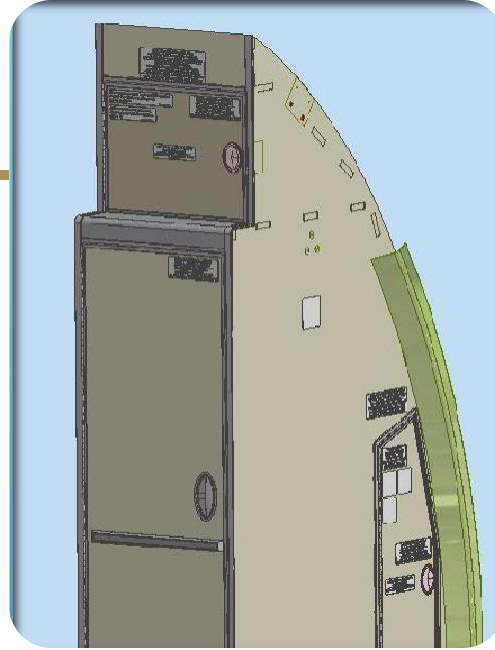

**JETMS**  
COMPLETIONS

# New Builds

Manufacture of AIRBUS A330 G10 galley unit

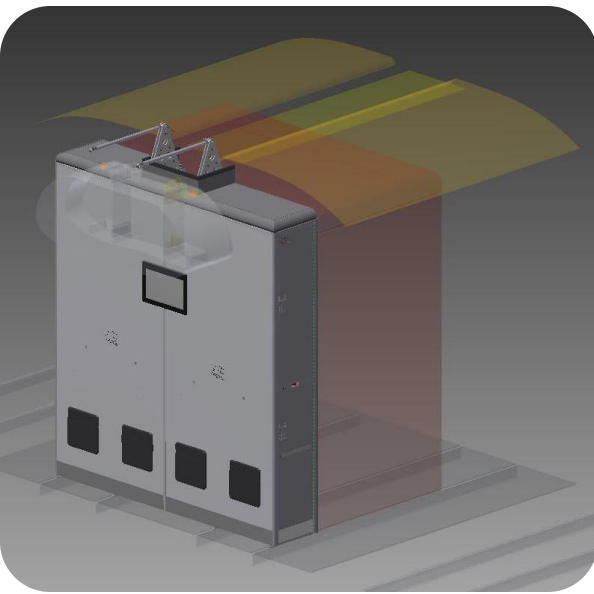
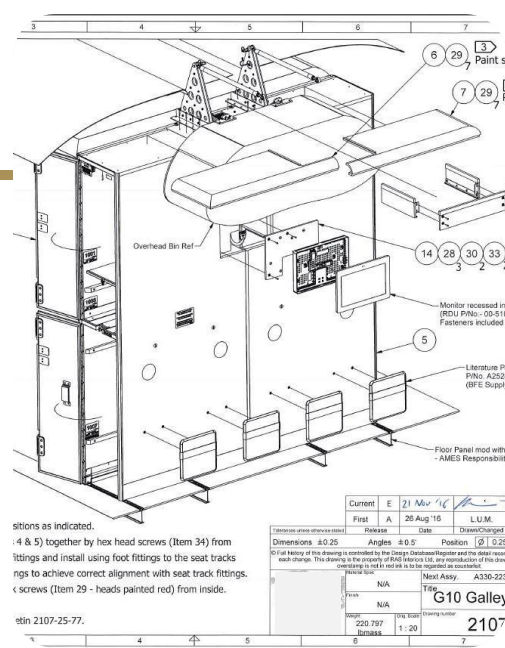

# New Builds

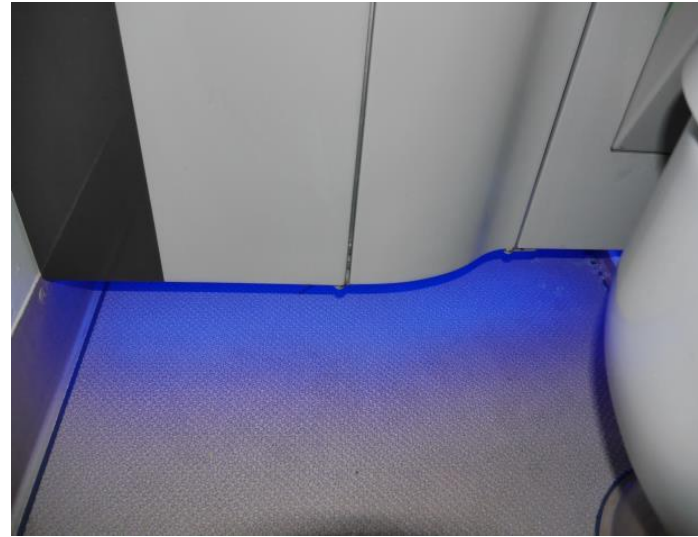
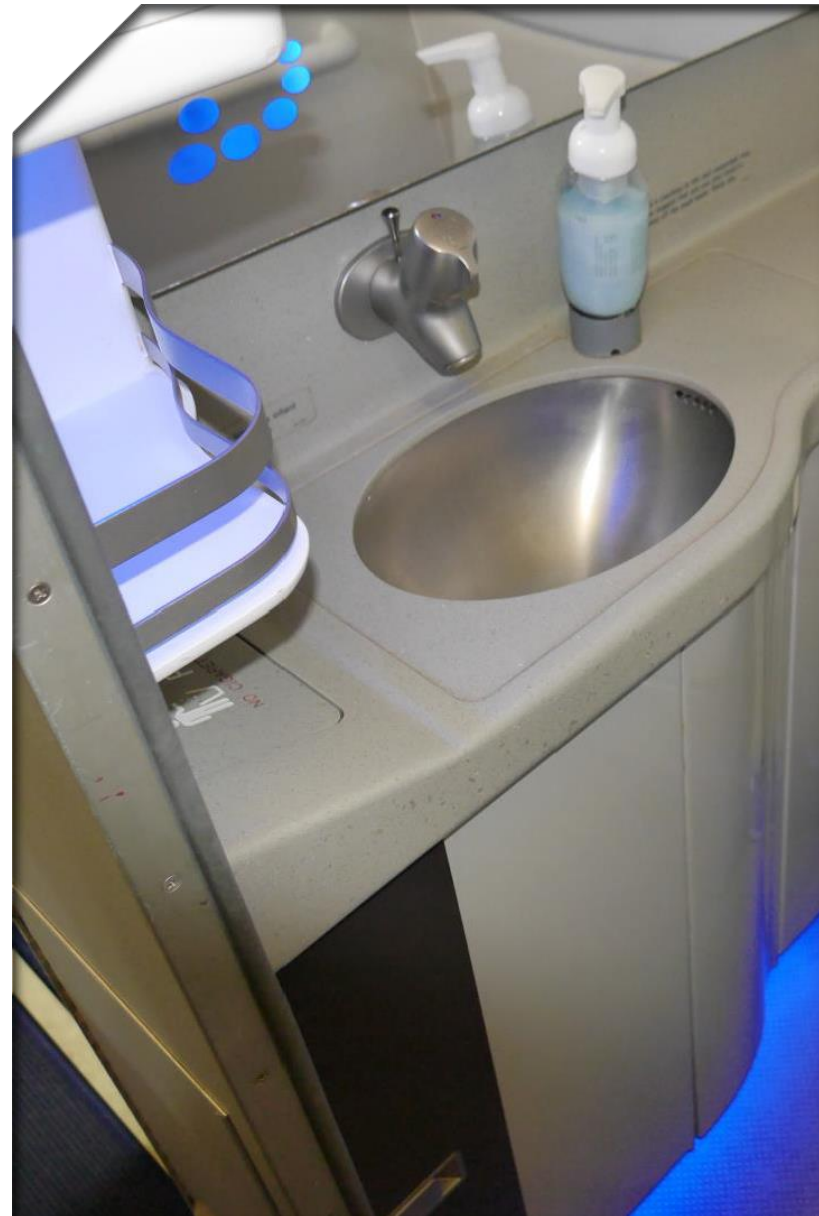

Lavatory upgrade for major European airline



# New Builds



Elevating crew comfort to new heights

Recognizing the crucial role that a well-rested crew plays in ensuring safe and efficient flight operations, we have crafted an oasis in the sky that seamlessly blends comfort, functionality, and simple, but comfortable design.



# New Builds

Completed interior for Head of State  
Voyager - AIRBUS A330

We offer a unique opportunity to create a full interior project for any type of aircraft, starting from a blank canvas.

Our seasoned team of designers and craftsmen specialize in transforming concepts into tangible, awe-inspiring realities. Whether it is a modern oasis in the sky or a classic masterpiece, we understand all preferences, lifestyle, and brand identity.



# New Builds



Out-board ottoman unit



# New Builds

Centre ottoman unit drawing design and 3D CAD model

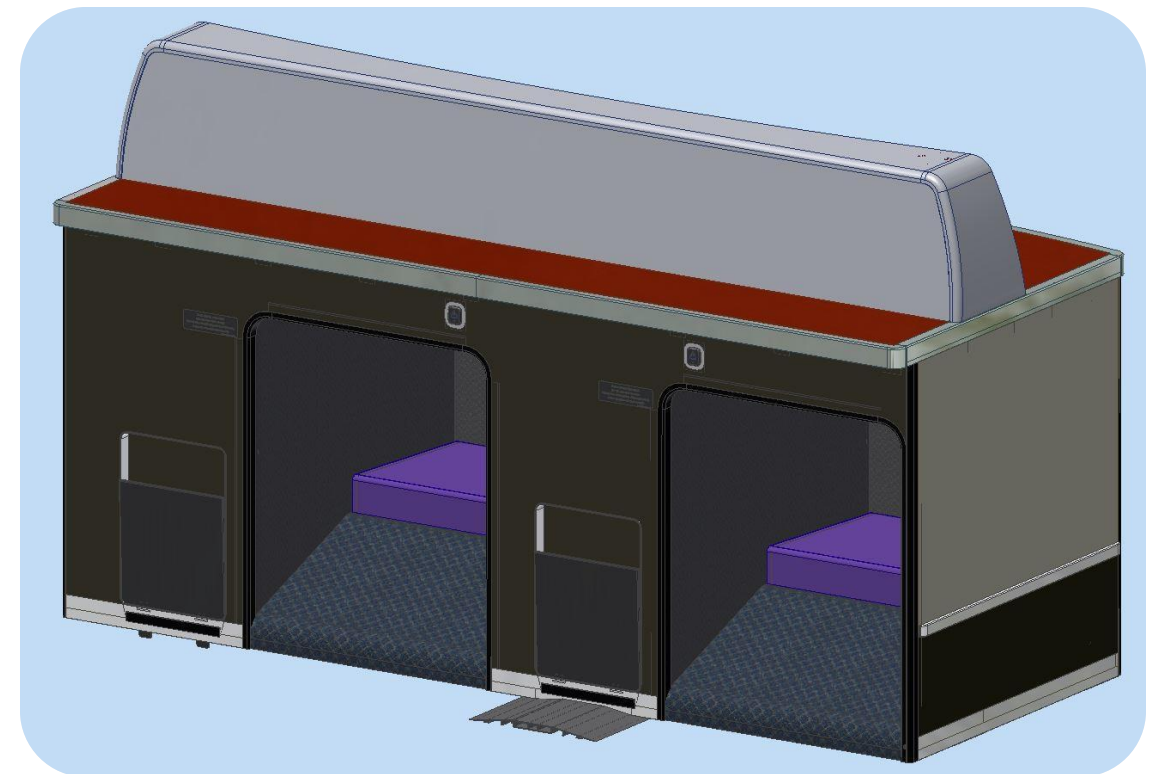
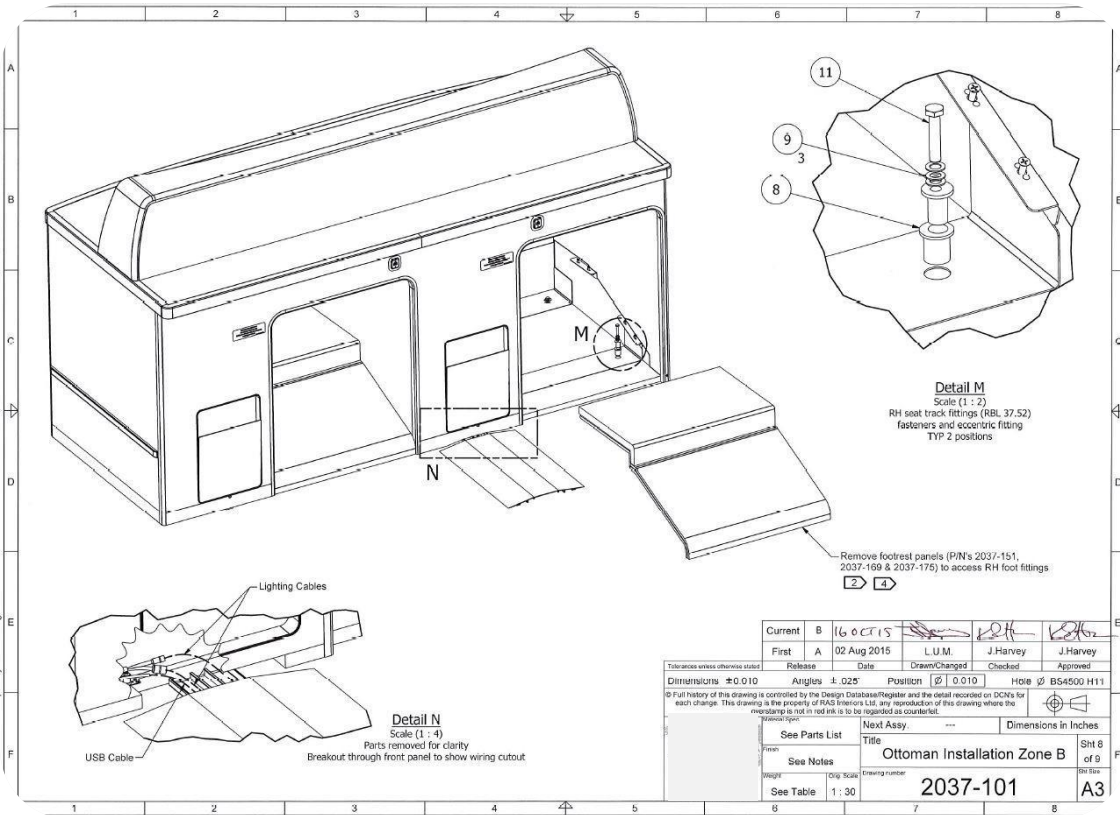

# New Builds



Front

Centre ottoman unit



Back

# New Builds

Changing room 3D wire frame isometric

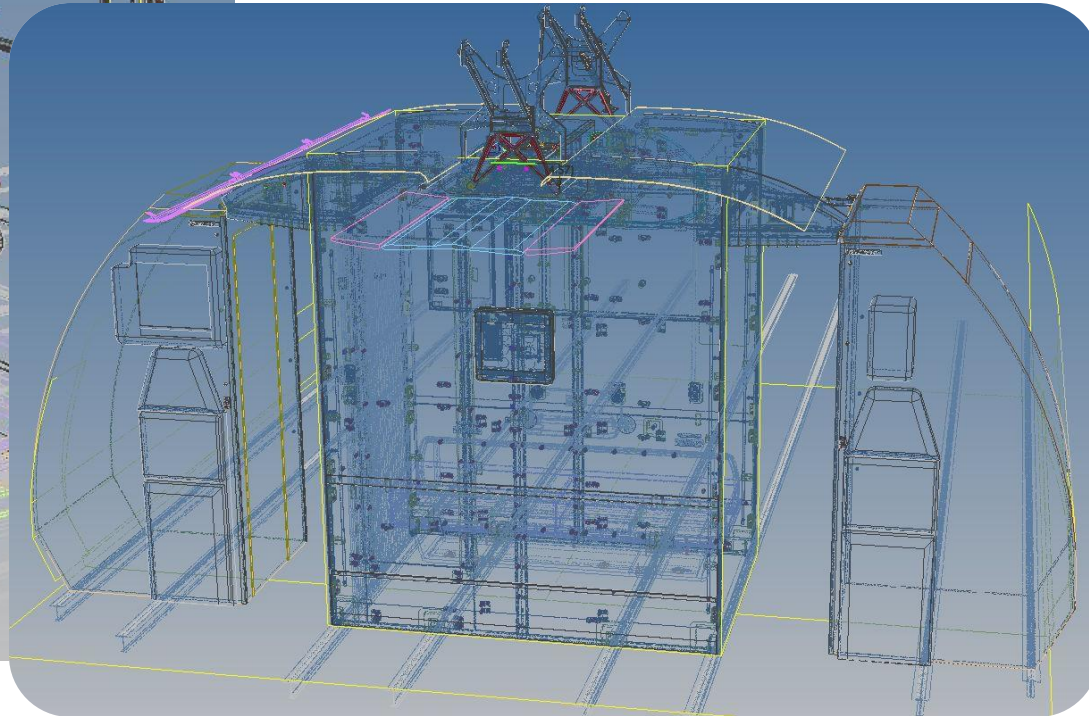
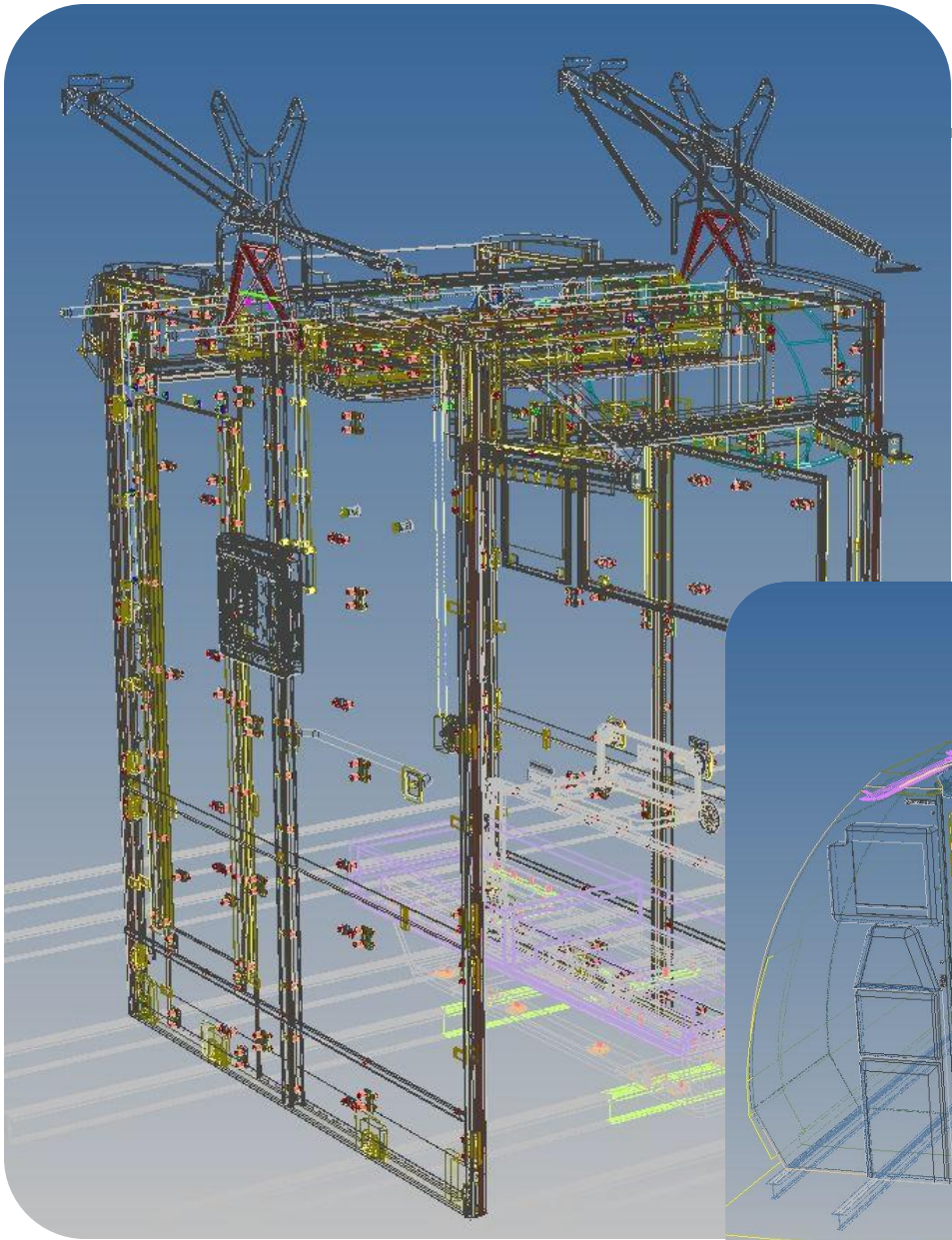

# New Builds

Changing Room 3D CAD Model

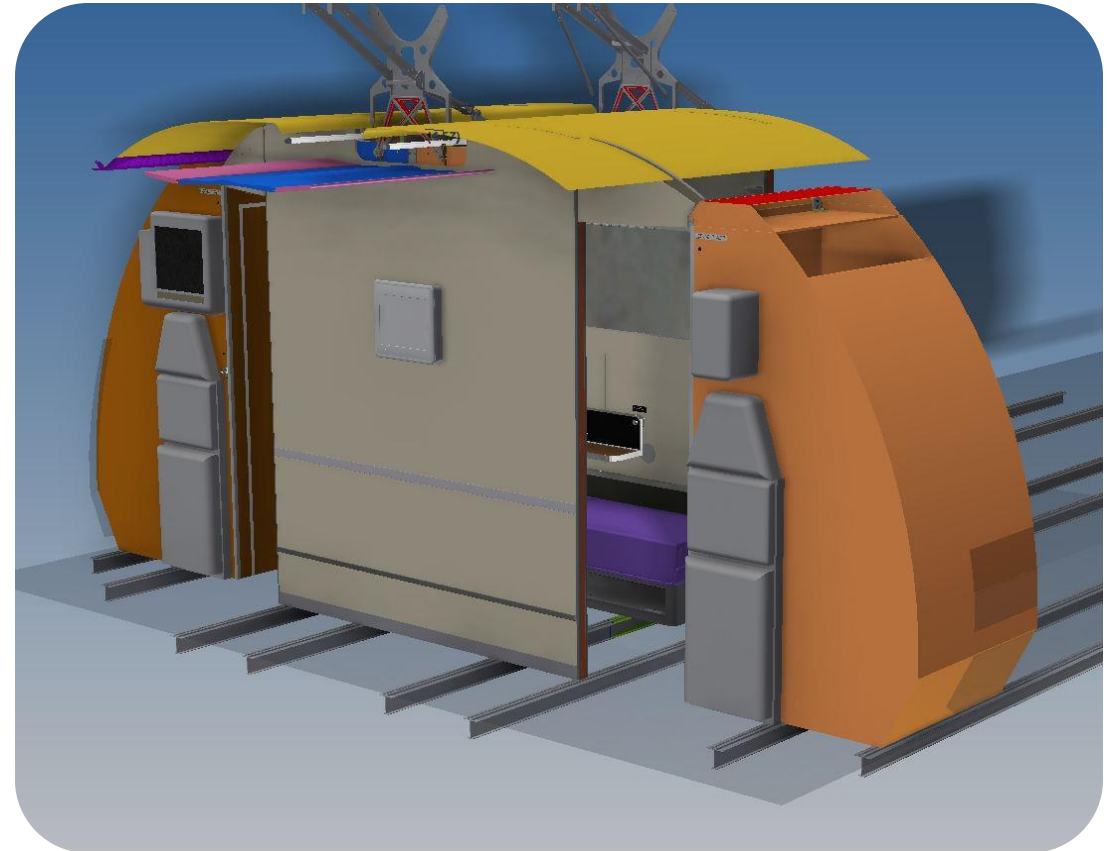
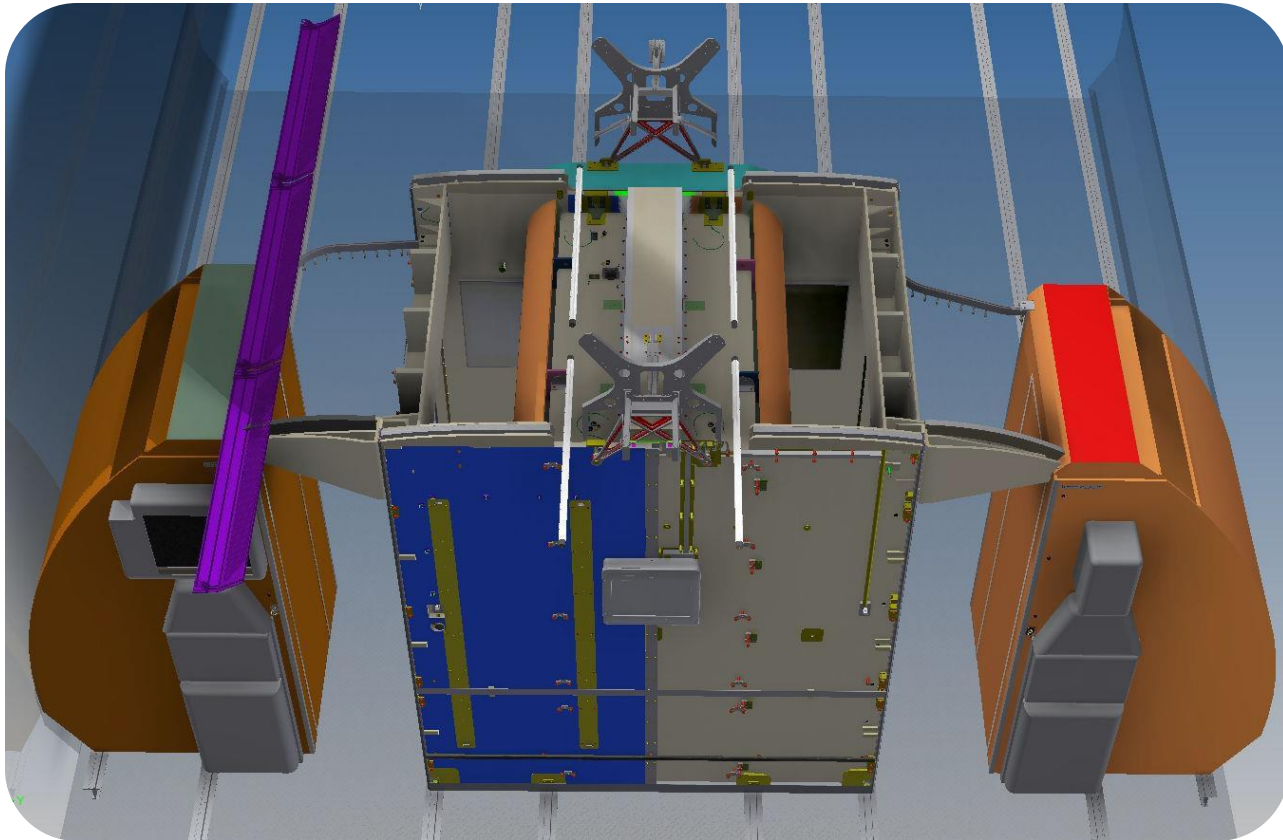

# New Builds

Changing Room 3D CAD Model

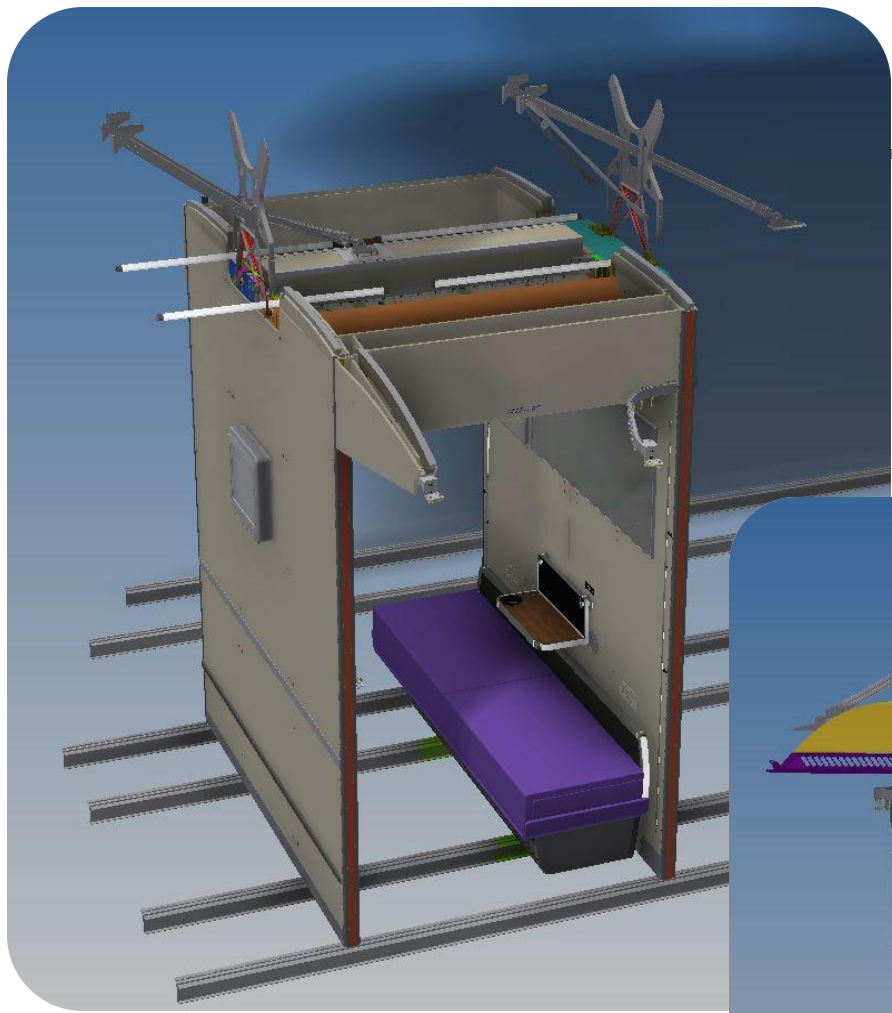



# New Builds



Changing Room Mock-Up

# New Builds

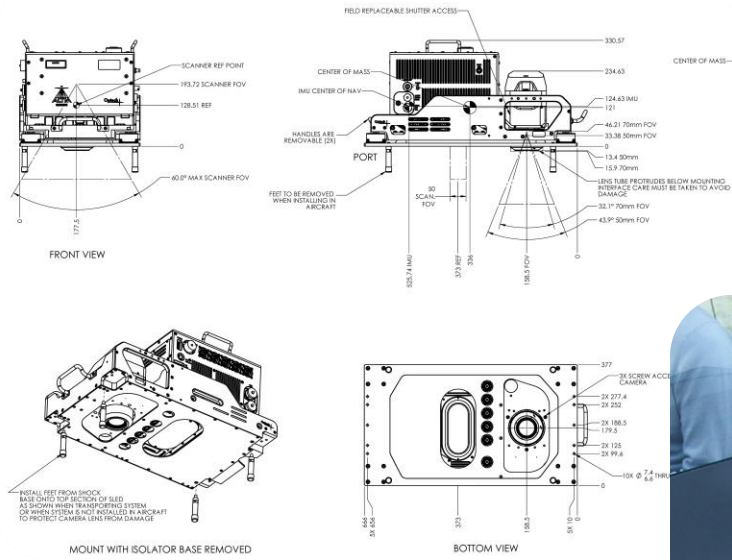

## Robinson Camera Mount

# New Builds

HELI-ONE Super Puma side ledge and pull-out table



**JETMS**  
COMPLETIONS

# New Builds

## SPECIAL orders

Elevating aircraft experience with bespoke special orders, where meticulous attention to detail meets innovation. Imagine custom-made metal plates seamlessly integrated into your aircraft's interior, showcasing both functionality and aesthetics. Our tailor-made drawer inserts not only optimize storage but also reflect a distinct style. These personalized touches redefine luxury in aviation, making every journey a testament to exclusivity and sophistication.





SOME OF OUR INTERIOR  
DESIGN PROJECTS











JETMS Completions Ltd

Bldg 510 Churchill Way London  
Biggin Hill Westerham England  
TN16 3BN

+44 (0) 1959 576 747

[info.completions@jetms.aero](mailto:info.completions@jetms.aero)

